

# HIGH SPEED DOME CAMERA

**User Manual**

**600 TVL**



# Table of contents

I	CAUTION	-----	4
II	INTRODUCTION OF PRODUCTS	-----	6
III	DIRECTIONS FOR USE	-----	14
IV	FUNCTIONAL SETTING BY THE KEYBOARD	-----	27
V	OSD MESSAGE DISCRIPTION	-----	30
VI	TROUBLE SHOOTING	-----	32
VII	DIMENSION	-----	34
VIII	ASSEMBLY	-----	36
IX	SPECIFICATION	-----	39

# I . CAUTION

Thank you for purchasing our product. Please operate the product after being fully aware of the manual. Please contact us if you have any queries.

## Precaution

Note the following matters before the installation of the product.

Avoid the following places for the installation.

A high/low temperature: Using indoor-cameras in the places of  $+50^{\circ}\text{C}$ ~  $-10^{\circ}\text{C}$  can cause troubles and lower its capacity.



Snow, rain and wet: Humidity or water and any liquid inside-camera can cause troubles.



Oil, gas: Oil and gas can damage the camera as they go through the cameras.



Vibration, shock: They bring on problems or errors of the camera.



Direct light, exposure to the air: In the case of that sets indoor- cameras outside where the weather is changeable, it can cause problems.



Closing to High frequency and electric power lines: Setting the camera up around electromagnetic units or power supplier can



## Caution in Use

Do not disassemble the unit and put alien substances in the unit.

- Disassembling the unit or putting alien substances such as a metal can make the camera defective.
- Make sure of power switch-off before the installation.
  - : Ensure power switch-off and check the voltage the camera before the installation.
- Do not give the unit a shock and an operation.
  - : Giving a strong shock or an excessive power on the button, terminal can cause problem.



This product has been designed and manufactured in accordance with the harmonized European standards, following the provisions of the below stated directives.

**Electromagnetic Compatibility Directive 89/336/EEC**

(EN60065:1998, EN61000-6-3:2001, EN61000-6-1:1997)

This device complies with part 15 of the FCC rules operation is subject to the following two conditions: (1) This device may not cause harmful interference and (2) This device must accept any interference received including interference that may cause undesired operation

**Caution :**

- ① Must use AC24V power source, current intensity must be less than 1.5A and must use a double winding transformer
- ② Never extend the power line from adaptor to camera.
- ③ Please use more thick cable than 18AWG(1.0mm), if you want to extend the power line.
- ④ You must use one adaptor per one camera that is being provided.
- ⑤ Use extra power supplier, If you want to supply many piece of cameras.

## II . INTRODUCTION OF PRODUCT

### 1. DESCRIPTION AND FEATURES

#### Description

This camera has been designed elegantly for buildings, department stores that need to be in harmony with the interior as a high speed dome camera, including various observation functions.

#### Features

☺ **High Resolution and Zoom Rate**

High resolution 600 TVL and Built-in High Zoom ( 27X, 33X, 37X )Rate Camera with 16x Digital Zoom

☺ **A low light function**

Surveillance with optimum picture is possible owing to digital-slow-shutter function. Digital-slow-shutter function is improving the CCD sensitivity by electrically lengthening exposure time so that it should be under surveillance on the condition of 0.00004Lux in B/W

☺ **Digital Wide Dynamic Range**

Wide-dynamic-range function is possible to look at object clearer in back light condition.

☺ **Digital Noise Reduction**

DNR significantly reduces the amount of low luminance noise.

☺ **Digital Image Stabilize**

There is some tremble as zoom magnification is high, the function can compensate the tremble.

☺ **HLC/User BLC Function**

The HLC settings selectively eliminates high lights in a limited.

☺ **Auto Tilt Function**

The unit can track the moving object automatically until 180° in vertical by using controller.

☺ **16 Privacy Masking Zones**

For the privacy, it can be programmed for masking zone up to 16 locations on the OSD menu screen. This function doesn't work on 27x speed dome camera.

☺ **250 Preset positions**

A maximum of 250 preset positions can be programmed. The preset function enables to set where you want on monitor at any time.

☺ **Various auto-surveillance functions**

Swing(2), Group(12 Presets), Tour(12 Groups), Spiral, Trace

☺ **Smart pan/tilt function**

Pan and tilt speed compensation function in proportion to depth of zoom.

## 2. INSTALLATION AND CONNECTION

### 1) Name and function of each part

Indoor Type

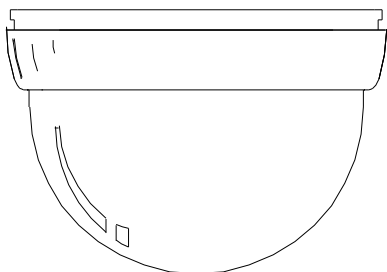
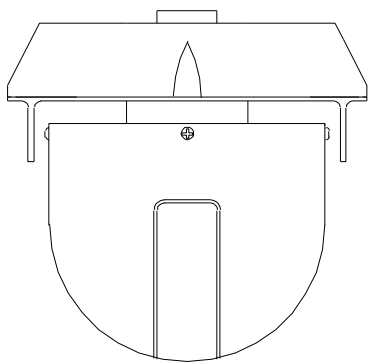
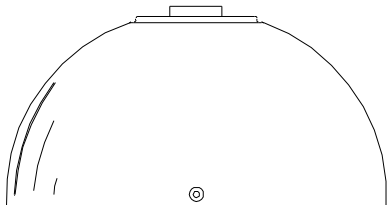

#### (UPPER COVER)

The camera's body goes to here and a power cable, data cable, video cable, sensor have been connected with this

#### (DOME DRIVER)

A main body that has a built-in the control units and camera

#### (LOWER COVER)

Insert the body into the upper cover, then close the lower cover

Outdoor Type

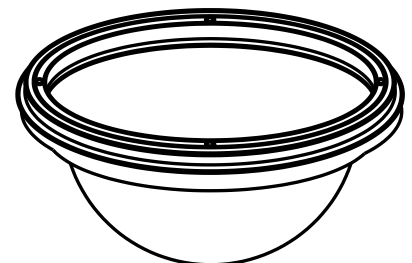
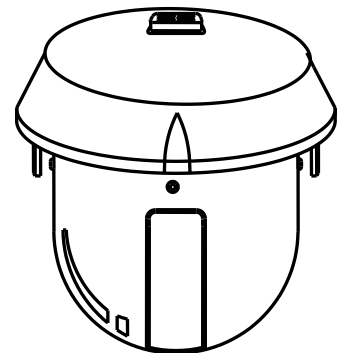
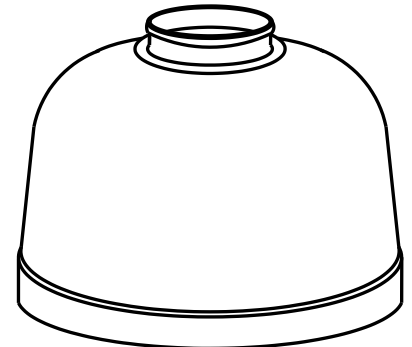

## 2) Installation

Indoor Type

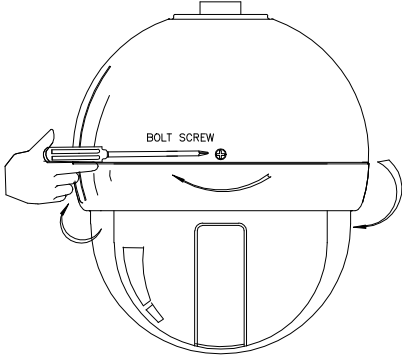

### SEPARATION OF LOWER COVER

(Indoor type)

Loosen the bolt of the back of lower cover by a screwdriver(+), then turn the cover as above the picture and pull the lower cover to the down

(Outdoor type)

Loosen the four bolts of the lower cover, then separate.

Outdoor Type

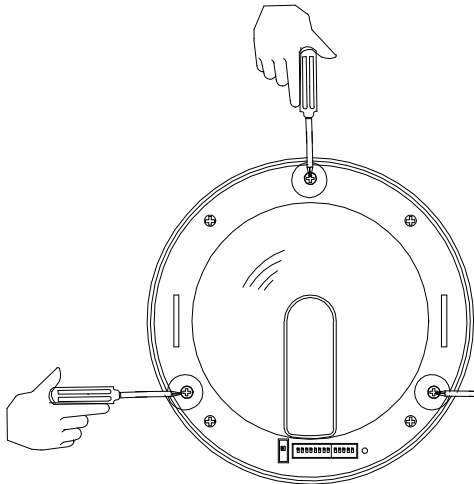
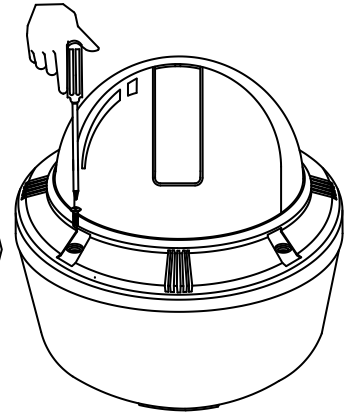

Loosen the three bolts, the round head shaped, of the camera body. The three bolts are not loosened completely and not come up more than 1cm of the lower cover, then separate.

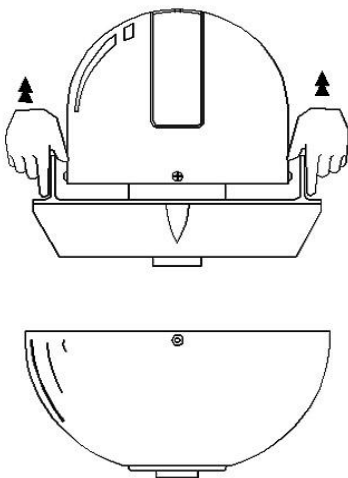
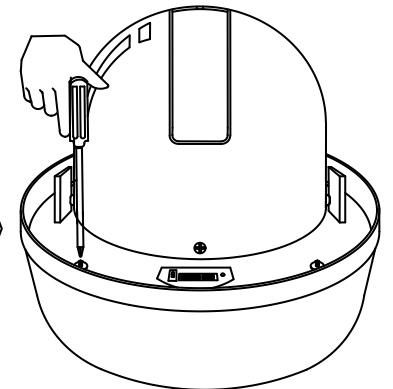

Pull the cover up with grabbing the bottom of the camera after loosening the three bolts

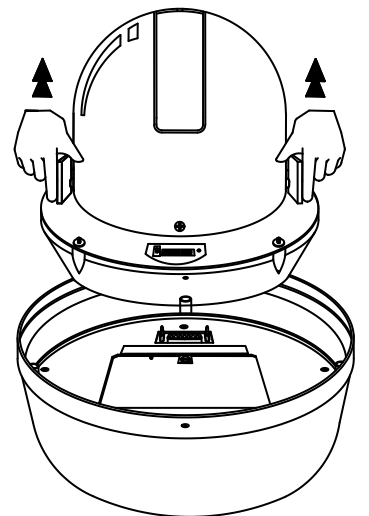



Open the connector cover, then connect power, data, video cable and sensor

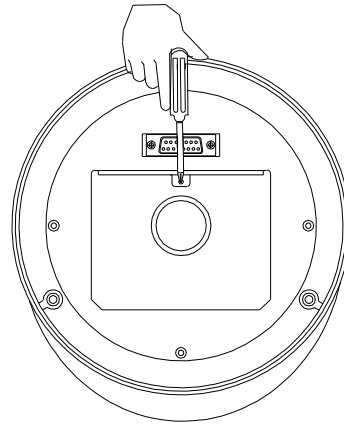

The cover is opened if user loosens the one bolt on the connector cover by using a screwdriver(+).

The bolts not loosened completely to protect from missing of them.

Be careful that each cable which each function is changed wrong

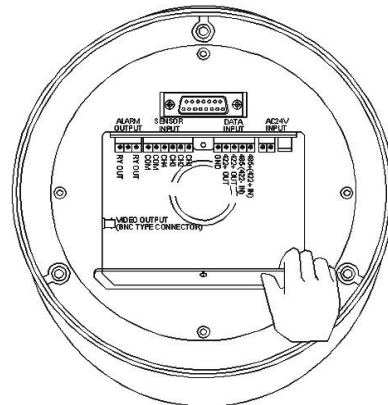

Have you connect the power cable in the right direction ?

If yes

- ① RED led, in the middle of the connector, is lighted
- ② Use AC24V power source and user can use any power input that is connected with a terminal and a jack (But use 1 input).

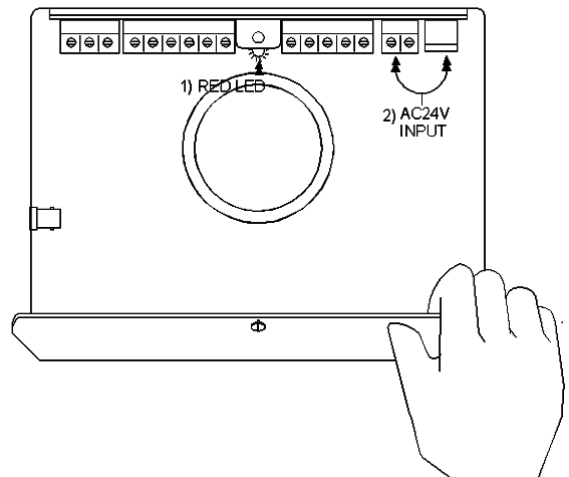

### 3) How to connect equipments

DC12V/1A adaptor and junction box are provided on a purchase, Junction box consists of 2 data ports ( Each data port can be connected with maximum up to 128 cameras and sub keyboard terminal

Connect the image line of a monitor

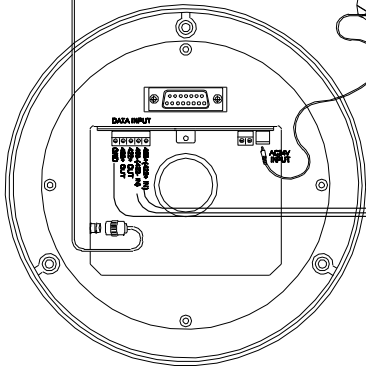

CAMERA 1

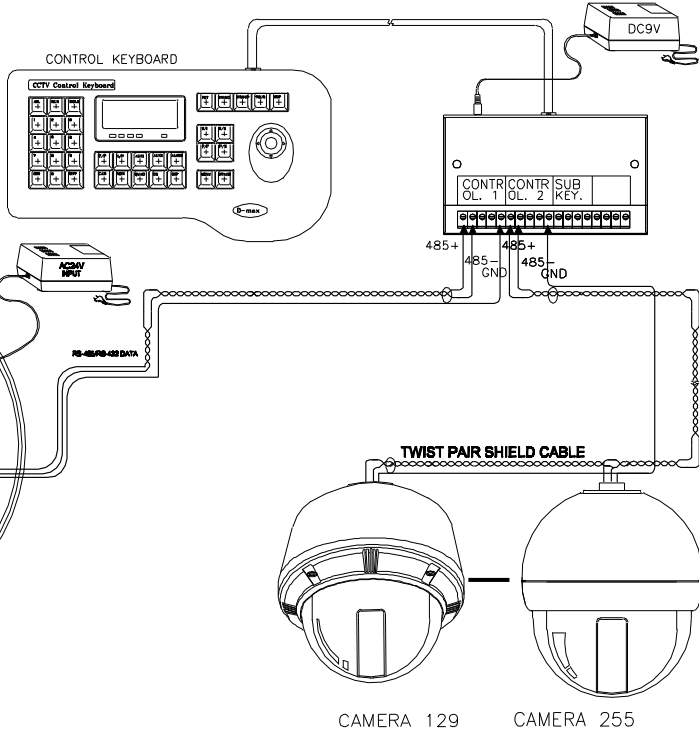

Reference to the following page.

User can control maximum up to 255 cameras connected by using the exclusive control keyboard. User can connect it maximum up to 1.2km when using twist pair shield cable as a connecting cable

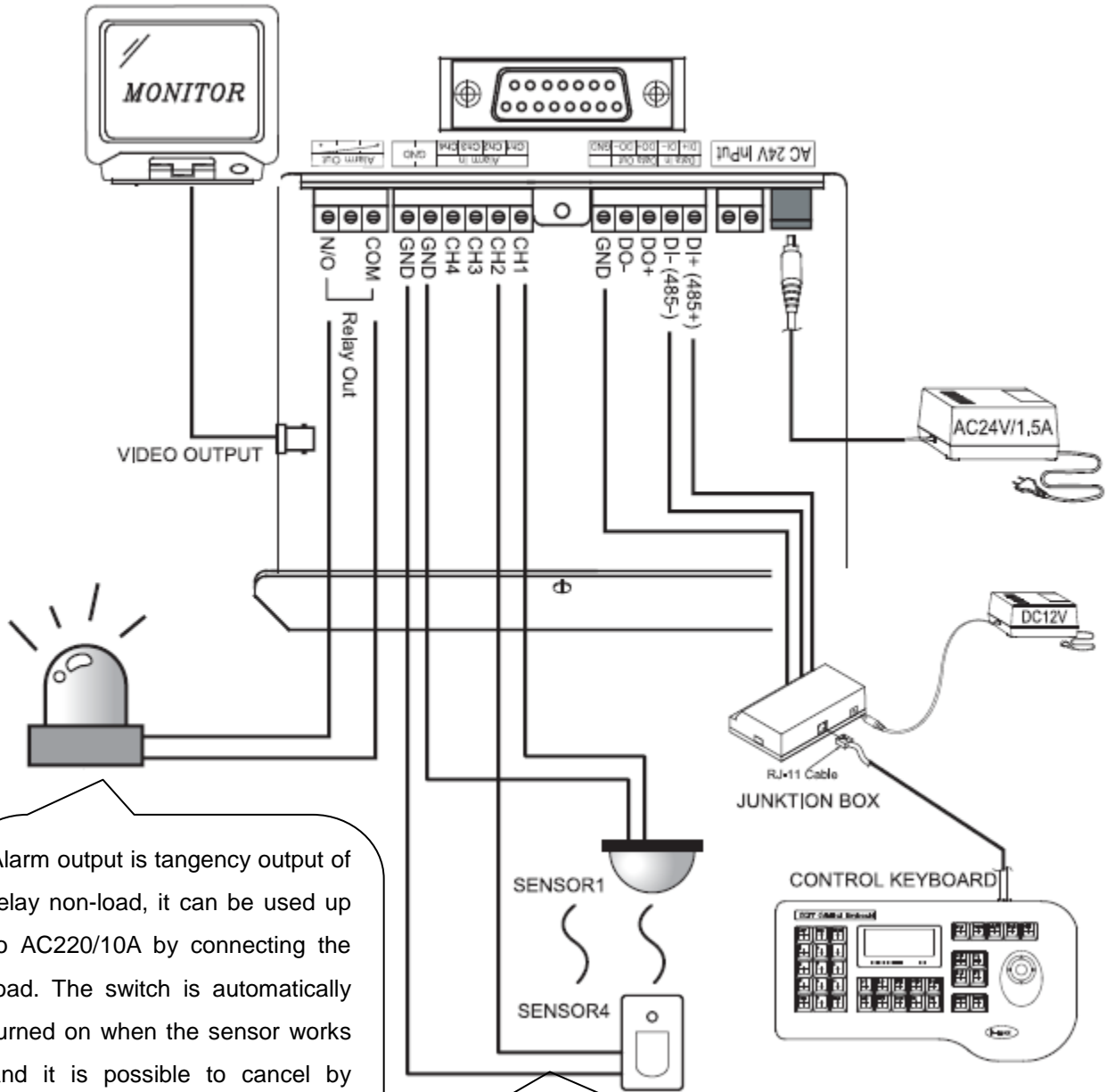

Alarm output is tangency output of relay non-load, it can be used up to AC220/10A by connecting the load. The switch is automatically turned on when the sensor works and it is possible to cancel by using the controller after a limited time

**The sensor**  
 Can be connected maximum 4 channels and the camera can be moved automatically to the point by preset mode,

**DATA**  
 Can be processed by RS485 or RS422 and use parallel connection to use a large quantity of cameras. ( Even if it must be used 2-twist paired cable in use of RS422, the terminal port which was connected with R485 cable port with 1-pair cable when it is not necessary to take a return data from camera

#### 4) HOW TO SET PROTOCOL

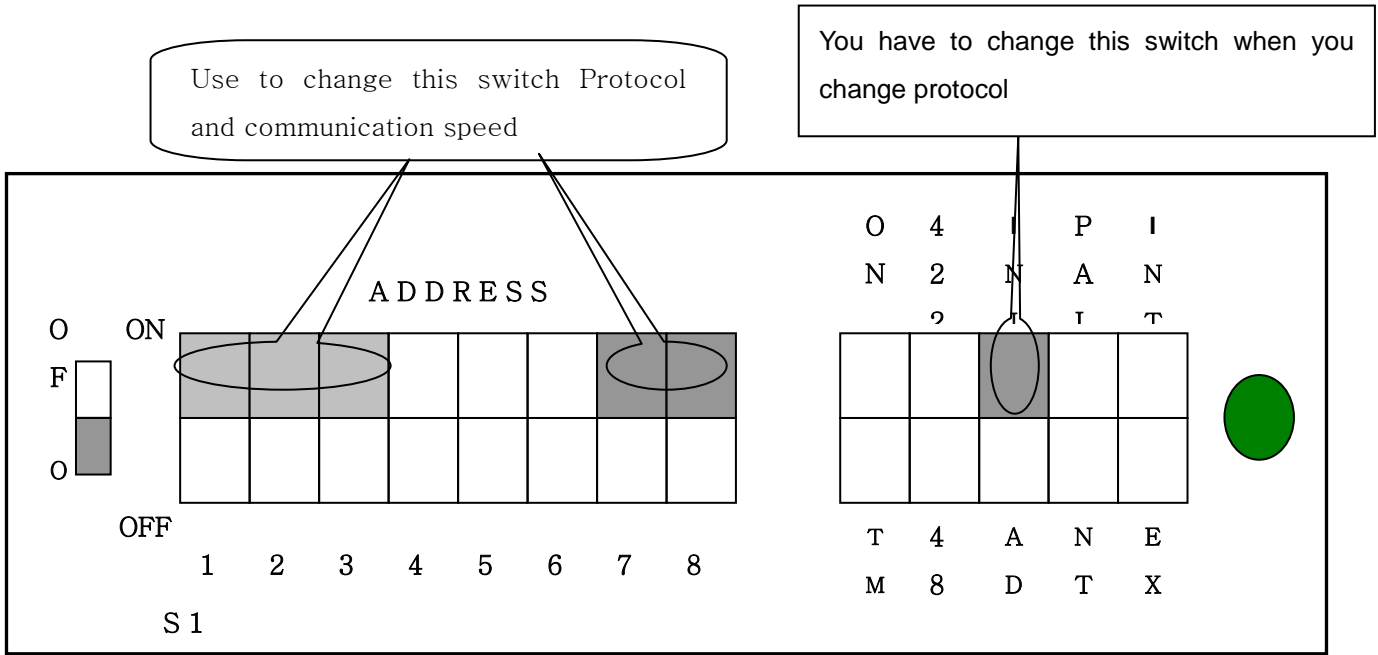

The switch to select protocol      The switch to select baud rate      Change No.3 of S2 to INIT if user wants to change protocol

PROTOCOL	S 1					S 2
	SW 1	SW 2	SW 3	SW 7	SW 8	SW 'INIT→ADDR'
D-MAX (9600 bps)	OFF	OFF	OFF	OFF	OFF	INIT
P-P (9600 bps)	ON	OFF	OFF	OFF	OFF	INIT
P-P (4800 bps)	ON	OFF	OFF	OFF	ON	INIT
P-P (2400 bps)	ON	OFF	OFF	ON	OFF	INIT
P-D (9600 bps)	OFF	ON	OFF	OFF	OFF	INIT
P-D (4800 bps)	OFF	ON	OFF	OFF	ON	INIT
P-D (2400 bps)	OFF	ON	OFF	ON	OFF	INIT
S-T (9600bps)	OFF	OFF	ON	OFF	OFF	INIT

- ① Please the power off
- ② Switch protocol that user wants to change on as above the cable
- ③ The power on, then the set protocol and baud rate are appealed.
- ④ The power off, if every setting is right. Then the change of protocol is finished.
- ⑤ Change No. 3 of S2 to ADDR before the power on, then the power on after setting the address of the camera.
- ⑥ Try it again with the information as above the table, if something is wrong

### 5) SETTING ADDRESS OF DIP SWITCHES.

RX NO	DIP SWITCH (HEX)							RX NO	DIP SWITCH (HEX)						
	1	2	3	4	5	6	7		1	2	3	4	5	6	7
1	ON	OFF	OFF	OFF	OFF	OFF	OFF	33	ON	OFF	OFF	OFF	OFF	ON	OFF
2	OFF	ON	OFF	OFF	OFF	OFF	OFF	34	OFF	ON	OFF	OFF	OFF	ON	OFF
3	ON	ON	OFF	OFF	OFF	OFF	OFF	35	ON	ON	OFF	OFF	OFF	ON	OFF
4	OFF	OFF	ON	OFF	OFF	OFF	OFF	36	OFF	OFF	ON	OFF	OFF	ON	OFF
5	ON	OFF	ON	OFF	OFF	OFF	OFF	37	ON	OFF	ON	OFF	OFF	ON	OFF
6	OFF	ON	ON	OFF	OFF	OFF	OFF	38	OFF	ON	ON	OFF	OFF	ON	OFF
7	ON	ON	ON	OFF	OFF	OFF	OFF	39	ON	ON	ON	OFF	OFF	ON	OFF
8	OFF	OFF	OFF	ON	OFF	OFF	OFF	40	OFF	OFF	OFF	ON	OFF	ON	OFF
9	ON	OFF	OFF	ON	OFF	OFF	OFF	41	ON	OFF	OFF	ON	OFF	ON	OFF
10	OFF	ON	OFF	ON	OFF	OFF	OFF	42	OFF	ON	OFF	ON	OFF	ON	OFF
11	ON	ON	OFF	ON	OFF	OFF	OFF	43	ON	ON	OFF	ON	OFF	ON	OFF
12	OFF	OFF	ON	ON	OFF	OFF	OFF	44	OFF	OFF	ON	ON	OFF	ON	OFF
13	ON	OFF	ON	ON	OFF	OFF	OFF	45	ON	OFF	ON	ON	OFF	ON	OFF
14	OFF	ON	ON	ON	OFF	OFF	OFF	46	OFF	ON	ON	ON	OFF	ON	OFF
15	ON	ON	ON	ON	OFF	OFF	OFF	47	ON	ON	ON	ON	OFF	ON	OFF
16	OFF	OFF	OFF	OFF	ON	OFF	OFF	48	OFF	OFF	OFF	OFF	ON	ON	OFF
17	ON	OFF	OFF	OFF	ON	OFF	OFF	49	ON	OFF	OFF	OFF	ON	ON	OFF
18	OFF	ON	OFF	OFF	ON	OFF	OFF	50	OFF	ON	OFF	OFF	ON	ON	OFF
19	ON	ON	OFF	OFF	ON	OFF	OFF	51	ON	ON	OFF	OFF	ON	ON	OFF
20	OFF	OFF	ON	OFF	ON	OFF	OFF	52	OFF	OFF	ON	OFF	ON	ON	OFF
21	ON	OFF	ON	OFF	ON	OFF	OFF	53	ON	OFF	ON	OFF	ON	ON	OFF
22	OFF	ON	ON	OFF	ON	OFF	OFF	54	OFF	ON	ON	OFF	ON	ON	OFF
23	ON	ON	ON	OFF	ON	OFF	OFF	55	ON	ON	ON	OFF	ON	ON	OFF
24	OFF	OFF	OFF	ON	ON	OFF	OFF	56	OFF	OFF	OFF	ON	ON	ON	OFF
25	ON	OFF	OFF	ON	ON	OFF	OFF	57	ON	OFF	OFF	ON	ON	ON	OFF
26	OFF	ON	OFF	ON	ON	OFF	OFF	58	OFF	ON	OFF	ON	ON	ON	OFF
27	ON	ON	OFF	ON	ON	OFF	OFF	59	ON	ON	OFF	ON	ON	ON	OFF
28	OFF	OFF	ON	ON	ON	OFF	OFF	60	OFF	OFF	ON	ON	ON	ON	OFF
29	ON	OFF	ON	ON	ON	OFF	OFF	61	ON	OFF	ON	ON	ON	ON	OFF
30	OFF	ON	ON	ON	ON	OFF	OFF	62	OFF	ON	ON	ON	ON	ON	OFF
31	ON	ON	ON	ON	ON	OFF	OFF	63	ON	ON	ON	ON	ON	ON	OFF
32	OFF	OFF	OFF	OFF	OFF	ON	OFF	64	OFF	OFF	OFF	OFF	OFF	OFF	ON

-No.1 is changed to No.64 and the last No.64 is changed No.128 when No.7 DIP SW is on.

-No.1 is changed to No.129 when No.7 DIP SW is off and No.8 DIP SW is on.

-No.1 is changed to No.193 and user can set up to maximum 255 ADDRESS when No.7, 8 DIP SW are on.

### III. DIRECTIONS FOR USE

- OSD (ON SCREEN DISPLAY) menu control

It is the function to call up the Menu

- \* User can not only set Preset, Group, Tour, Swing, Trace functions of the camera up by the menu, but also set them up by shortening keys.

- Accessing OSD menu

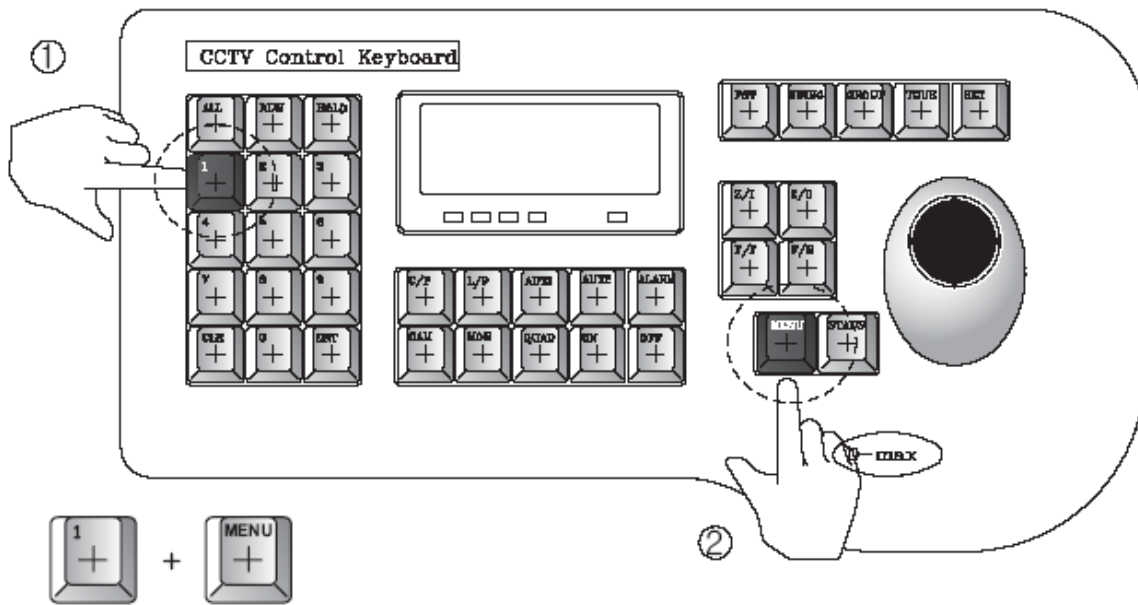

- The menu is displayed on the screen with the key tone when user presses No.1 and menu key.

◀◀ CAMERA SETUP p1 ▶▶

1. ID Set	: CAM-001
2. OSD Display.	: ID + Status
3. H-V Reverse.	: Normal
4. AGC Control	: Max
5. Shutter speed.	: AUTO
6. Sharpness level	: 6
7. Brightness	: 9
8. Flickerless	: OFF
9. DNR Control	: Medium
- NEXT MENU PAGE	

- OSD Menu Control Up, Down, Right and Left moving of Cursor like under pictures



- Cancellation of OSD menu



◀◀ CAMERA SETUP p1 ▶▶

- 1. ID Set : CAM-001
  - 2. OSD Display. : ID + Status
  - 3. H-V Reverse. : Normal
  - 4. AGC Control : Max
  - 5. Shutter speed. : AUTO
  - 6. Sharpness level : 6
  - 7. Brightness : 9
  - 8. Flickerless : OFF
  - 9. DNR Control : Medium
- NEXT MENU PAGE

**1. ID SET.**

This function is to set camera ID up to 16 letters on the monitor.

User can choose letters that they want, if user control a joystick up / down / right / left, and user can reselect the

previous letters, if user presses Z/I, Z/O or turn the head of the joystick to right/left

<< SET ID [ ●●●●●● CAM-001 ] >>

●!#\$%&()\*+`-./0123456789  
 ::<=>?@ABCDEFGHIJKLMNPOQ  
 RSTUVWXYZ[\]^\_`abcdefghijklmnopqrstuvwxyz

Zoom In/Out , OSD Shift  
 Press SAVE F/F , ESC F/N

◀◀ CAMERA SETUP p1 ▶▶

- 1. ID Set : CAM-001
  - 2. OSD Display. : ID + Status
  - 3. H-V Reverse. : Normal
  - 4. AGC Control : Max
  - 5. Shutter speed. : AUTO
  - 6. Sharpness level : 6
  - 7. Brightness : 9
  - 8. Flickerless : OFF
  - 9. DNR Control : Medium
- NEXT MENU PAGE

**2. OSD DISPLAY.**

Set up whether user sets ID and STATUS to display on the screen in normal operating.

- ID + Status: 'ID' and 'Status' displayed on the screen
- ID only: Only 'ID' displayed on the screen
- Status only: Only 'Status' displayed on the screen
- All off: Nothing displayed on the screen

◀◀ CAMERA SETUP p1 ▶▶

- 1. ID Set : CAM-001
  - 2. OSD Display. : ID + Status
  - 3. H-V Reverse. : Normal
  - 4. AGC Control : Max
  - 5. Shutter speed. : AUTO
  - 6. Sharpness level : 6
  - 7. Brightness : 9
  - 8. Flickerless : OFF
  - 9. DNR Control : Medium
- NEXT MENU PAGE

**3. H-V REVERSE**

Set up H-V reverse mode.

- Normal
- H-REV : You can flip the picture horizontally on the screen.
- V-REV : You can flip the picture vertically on the screen.
- HV-REV : You can flip the picture horizontally and vertically on the screen.

◀◀ CAMERA SETUP p1 ▶▶

- 1. ID Set : CAM-001
  - 2. OSD Display. : ID + Status
  - 3. H-V Reverse. : Normal
  - 4. AGC Control : Max
  - 5. Shutter speed. : AUTO
  - 6. Sharpness level : 6
  - 7. Brightness : 9
  - 8. Flickerless : OFF
  - 9. DNR Control : Medium
- NEXT MENU PAGE

**4. AGC CONTROL**

AGC(Automatic Gain Control)- It adjusts the amount of video amplification to maintain a full 1-volt peak-to-peak video signal output automatically.

- ▶ Low, Medium, Max

◀◀ CAMERA SETUP p1 ▶▶

- 1. ID Set : CAM-001
  - 2. OSD Display. : ID + Status
  - 3. H-V Reverse. : Normal
  - 4. AGC Control : Max
  - 5. Shutter speed. : AUTO**
  - 6. Sharpness level : 6
  - 7. Brightness : 9
  - 8. Flickerless : OFF
  - 9. DNR Control : Medium
- NEXT MENU PAGE

### 5. SHUTTER SPEED

As a setting shutter speed mode, it can be distinguished a fast moving subject easily by means of shutter speed up.

※ Attention-The illumination of the camera decreases if shutter speed is up.

※ The state of first default is 'AUTO'.

※ It can be worked in the state of Flickerless 'off'

▶ Range : Auto, 1/125, 1/250, 1/500, --- 1/120000

◀◀ CAMERA SETUP p1 ▶▶

- 1. ID Set : CAM-001
  - 2. OSD Display. : ID + Status
  - 3. H-V Reverse. : Normal
  - 4. AGC Control : Max
  - 5. Shutter speed. : AUTO
  - 6. Sharpness level : 6**
  - 7. Brightness : 9
  - 8. Flickerless : OFF
  - 9. DNR Control : Medium
- NEXT MENU PAGE

### 6. SHARPNESS LEVEL

Compensation of the shape of a subject

▶ Range : 0 ~ 10, Default : 6

◀◀ CAMERA SETUP p1 ▶▶

- 1. ID Set : CAM-001
  - 2. OSD Display. : ID + Status
  - 3. H-V Reverse. : Normal
  - 4. AGC Control : Max
  - 5. Shutter speed. : AUTO
  - 6. Sharpness level : 6
  - 7. Brightness : 9**
  - 8. Flickerless : OFF
  - 9. DNR Control : Medium
- NEXT MENU PAGE

### 7. BRIGHTNESS

Control brightness of a screen.

The screen gets dark because an iris is closed as the numerical value is low, whereas the screen gets bright because an iris is opened as the numerical value is high.

▶ Range: 0~19, Default: 9

◀◀ CAMERA SETUP p1 ▶▶

- 1. ID Set : CAM-001
  - 2. OSD Display. : ID + Status
  - 3. H-V Reverse. : Normal
  - 4. AGC Control : Max
  - 5. Shutter speed. : AUTO
  - 6. Sharpness level : 6
  - 7. Brightness : 9
  - 8. Flickerless : OFF**
  - 9. DNR Control : Medium
- NEXT MENU PAGE

### 8. FLICKERLESS

Tremble on the screen is removed in the state of FLICKERLESS 'ON', the shutter speed, at the same time, is fixed in 1/120sec in NTSC and in 1/100sec in PAL.

▶ Off, Manual, On



◀◀ CAMERA SETUP p1 ▶▶

- 1. ID Set : CAM-001
- 2. OSD Display. : ID + Status
- 3. H-V Reverse. : Normal
- 4. AGC Control : Max
- 5. Shutter speed. : AUTO
- 6. Sharpness level : 6
- 7. Brightness : 9
- 8. Flickerless : OFF
- 9. DNR Control : Medium**
- NEXT MENU PAGE

### 9. DNR Control

It can remarkably reduce noise of minimum illumination by super noise removable technique and also file size becomes smaller while DVR is being recorded by the effective reduction of noise.

- ▶ Off, Low, Medium, Max

◀◀ CAMERA SETUP p2 ▶▶

- 10. Back Light : WDR Mode**
- 11. Set Back Light Mode
- 12. White Balance : Auto
- 13. Focus Mode : Oneshot
- 14. Zoom Max Limit : Off
- 15. DSS Control : 10 Field
- 16. Day&Night : Auto+Hi
- 17. Stabilize On/Off : Off
- PREV MENU PAGE
- NEXT MENU PAGE

### 10. BACK LIGHT

This camera is designed so that it delivers a distinctive subject and background at the same time, even when the subject is in backlight, unlike conventional cameras, by adopting a proprietary DSP chip.

.Please select a suitable mode below them (The Set Back Light Mode will be automatically changed by the selection)

- ▶ Off, WDR MODE, HLC MODE, BLC MODE

this mode makes both areas distinctive.

**BLC** : Enables a user to directly select a desired area from a picture, and to view the area more clearly..

**HLC(High Light Compensation)** : If there is a high light installed in dark environment such as an apartment parking garage or gas station entrance, removing the high light makes it possible to view car license plates efficiently

**OFF** : Deactivates the BACKLIGHT function.

**WDR** : When there are both bright and dark areas at the same time,

◀◀ CAMERA SETUP p2 ▶▶

- 10. Back Light : WDR Mode
- 11. Set Back Light Mode**
- 12. White Balance : Auto
- 13. Focus Mode : Oneshot
- 14. Zoom Max Limit : Off
- 15. DSS Control : 10 Field
- 16. Day&Night : Auto+Hi
- 17. Stabilize On/Off : Off
- PREV MENU PAGE
- NEXT MENU PAGE

### 11. SET BACK LIGHT MODE

#### ▶ WDR MODE

- Limit: Adjust the WDR Sensitivity by selecting Low or Max
- Level: Adjust the WDR Brightness by controlling 0~15.

#### ▶ HLC(High Light Compensation)MODE

- Limit: Adjust the HLC Sensitivity by selecting Low, Medium or Max
- Level: Adjust the WDR Brightness by controlling 0~15.
- This Function only operate in nighttime.

#### ▶ BLC MODE : Select BLC mode or BLC Set area mode by using

the joystick.

- BLC Level: Adjust the BLC Sensitivity by selecting Low, Medium or Max

- BLC Set AREA (Press F/F): Set BLC area location and size

- Select F/F button, and set the BLC area by using the joystick, and set are size by using Z/I, Z/O buttons.

(The monitor shows as Exit BLC set(Press F/N)

After complete all setup, press F/N button, and then move to RETURN MENU PAGE. It is automatically saved.

◀◀ CAMERA SETUP p2 ▶▶

- 10. Back Light : WDR Mode
- 11. Set Back Light Mode
- 12. White Balance : Auto**
- 13. Focus Mode : Oneshot
- 14. Zoom Max Limit : Off
- 15. DSS Control : 10 Field
- 16. Day&Night : Auto+Hi
- 17. Stabilize On/Off : Off
- PREV MENU PAGE
- NEXT MENU PAGE

**12. WHITE BALANCE**

It prevents from that white color is changed as illumination, user can set it up in 2 ways.

- ▶ Auto, Indoor, Outdoor

◀◀ CAMERA SETUP p2 ▶▶

- 10. Back Light : WDR Mode
- 11. Set Back Light Mode
- 12. White Balance : Auto
- 13. Focus Mode : Oneshot**
- 14. Zoom Max Limit : Off
- 15. DSS Control : 10 Field
- 16. Day&Night : Auto+Hi
- 17. Stabilize On/Off : Off
- PREV MENU PAGE
- NEXT MENU PAGE

**13. FOCUS MODE**

Change Focus Mode to hand-worked or auto.

- ▶ OneShot : Auto Focusing mode works during non-working after zoom is worked.
- ▶ Auto: It adjusts the focus automatically as it monitors the screen.
- ▶ Manual: User can control the focus by hand-worked.

◀◀ CAMERA SETUP p2 ▶▶

- 10. Back Light : WDR Mode
- 11. Set Back Light Mode
- 12. White Balance : Auto
- 13. Focus Mode : Oneshot
- 14. Zoom Max Limit : Off**
- 15. DSS Control : 10 Field
- 16. Day&Night : Auto+Hi
- 17. Stabilize On/Off : Off
- PREV MENU PAGE
- NEXT MENU PAGE

**14. ZOOM MAX Limit**

It is used when user corrects and limits the extensional range of the focus as a function to set the maximum value of zoom.

- ▶ Off,
- ▶ 27x zoom : 54X ~ 432X
- 33x zoom : 66X ~ 528X
- 37x zoom : 74X ~ 592X

◀◀ CAMERA SETUP p2 ▶▶

- 10. Back Light : WDR Mode
- 11. Set Back Light Mode
- 12. White Balance : Auto
- 13. Focus Mode : Oneshot
- 14. Zoom Max Limit : Off
- 15. DSS Control : 10 Field**
- 16. Day&Night : Auto+Hi
- 17. Stabilize On/Off : Off
- PREV MENU PAGE
- NEXT MENU PAGE

**15. DSS CONTROL**

An object becomes clear as the field value gets higher in illumination, whereas a moving object becomes dim.

- ▶ Range : Off, 2 ~ 512 fields

◀◀ CAMERA SETUP p2 ▶▶

- 10. Back Light : WDR Mode
- 11. Set Back Light Mode
- 12. White Balance : Auto
- 13. Focus Mode : Oneshot
- 14. Zoom Max Limit : Off
- 15. DSS Control : 10 Field
- 16. Day&Night : Auto+Hi**
- 17. Stabilize On/Off : Off
- PREV MENU PAGE
- NEXT MENU PAGE

## 16. DAY& NIGHT

The function is used to distinguish an object clearly in the dark condition.

- ▶ Auto-Low : This mode is worked automatically according to sensitivity, if the sensitivity is low
- ▶ Auto-Hi : This mode is worked automatically according to sensitivity, if the sensitivity is high.
- ▶ On : Change into DAY & NIGHTY mode by hand-worked
- ▶ Off : Set DAY & NIGHTY mode 'off'

◀◀ CAMERA SETUP p2 ▶▶

- 10. Back Light : WDR Mode
- 11. Set Back Light Mode
- 12. White Balance : Auto
- 13. Focus Mode : Oneshot
- 14. Zoom Max Limit : Off
- 15. DSS Control : 10 Field
- 16. Day&Night : Auto+Hi
- 17. Stabilize On/Off : Off**
- PREV MENU PAGE
- NEXT MENU PAGE

## 17. STABILIZE On/Off

There is some tremble as zoom magnification is high, the function can compensate the tremble.

- ▶ On / Off

◀◀ CAMERA SETUP p3 ▶▶

- 18. Select Alarm : Sensor**
- 19. Motion Detection : Off
- 20. Preset Set & Run Page
- 21. Trace Set Page
- 22. Alarm CH On/Off Page
- 23. Alarm Preset Set Page
- 24. Privacy Zone Set Page
- PREV MENU PAGE
- NEXT MENU PAGE

## 18. SELECT ALARM

Tremble on the screen is removed in the state of FLICKERLESS 'ON', the shutter speed, at the same time, is fixed in 1/120sec in NTSC and in 1/100sec in PAL.

Alarm CH On/Off Page

◀◀ CAMERA SETUP p3 ▶▶

- 18. Select Alarm : Sensor
- 19. Motion Detection : Off**
- 20. Preset Set & Run Page
- 21. Trace Set Page
- 22. Alarm CH On/Off Page
- 23. Alarm Preset Set Page
- 24. Privacy Zone Set Page
- PREV MENU PAGE
- NEXT MENU PAGE

## 19. Motion Detection

Set Motion 'On' after move the camera where user wants.

It displays the message 'Motion Detected' on the screen when the moving of an object is sensed on the same screen.

◀◀ CAMERA SETUP p3 ▶▶

- 18. Select Alarm : Sensor
- 19. Motion Detection : Off
- 20. Preset Set & Run Page**
- 21. Trace Set Page
- 22. Alarm CH On/Off Page
- 23. Alarm Preset Set Page
- 24. Privacy Zone Set Page
- PREV MENU PAGE
- NEXT MENU PAGE

**20. PRESET SET & RUN PAGE**

It is a function to set and operate Preset, Group, Tour.

User can see the screen when moves the joystick to Right/Left after fixing the cursor on the menu.

<<PRESET SETUP PAGE>>

① Preset set CH :

User can set Preset No. and title on this menu.

- Preset No. set : Set it by moving the joystick to Right/Left
- Preset title set : User can see the menu "SET ID" when

press F/F key after setting Preset No

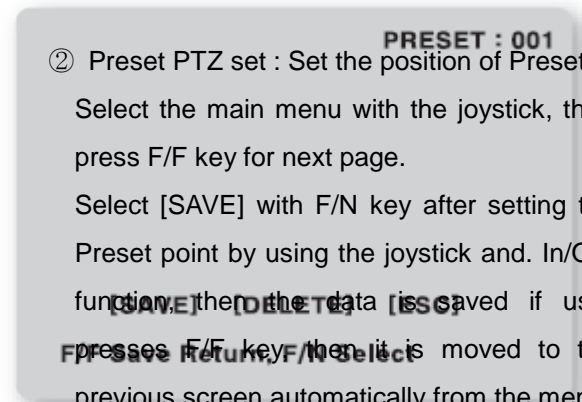
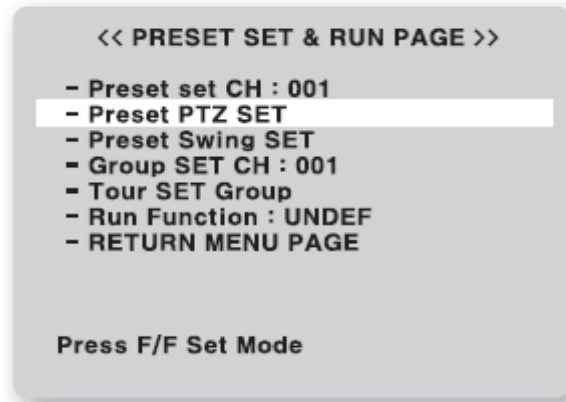
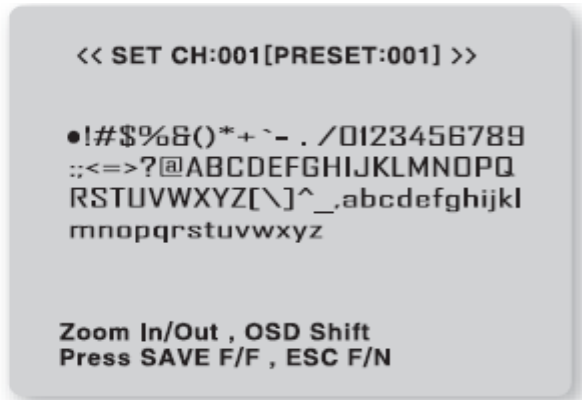
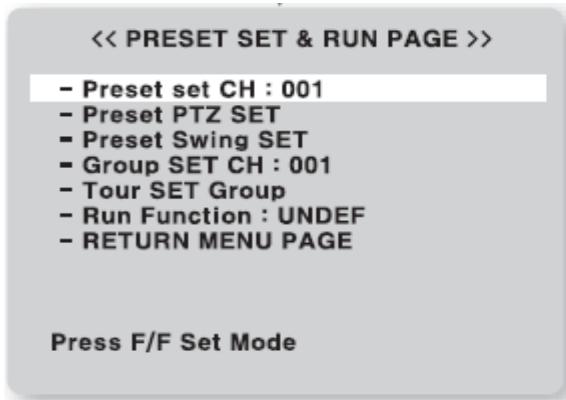

- ② Preset PTZ set : Set the position of Preset
- Select the main menu with the joystick, then press F/F key for next page.
- Select [SAVE] with F/N key after setting the Preset point by using the joystick and. In/Out function, then the data is saved if user presses F/F key, then it is moved to the previous screen automatically from the menu

※ Repeat the same way after changing the number of Preset, if user set another Preset

•[SAVE]: Previous screen. [DELETE]: Remove. [ESC]: Cancel



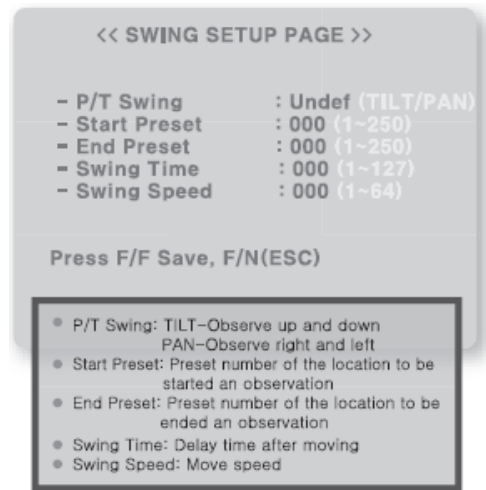
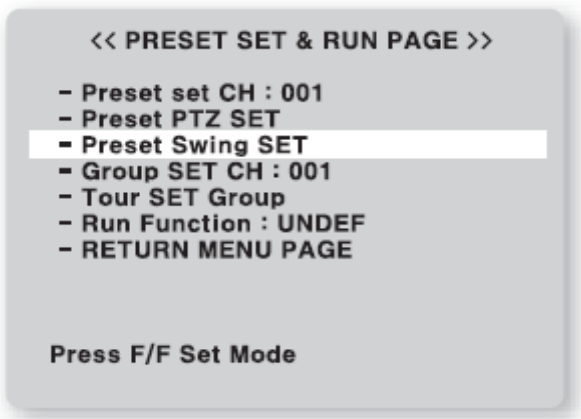

③ Preset Swing SET : Set Preset Swing  
 Move next SWING page for the setting, if user presses F/F key in the state of selection of the menu  
 ※ The preset must be set before the setting as Swing is a function to repeat an auto observation of 2 Preset points user fixes in Preset set

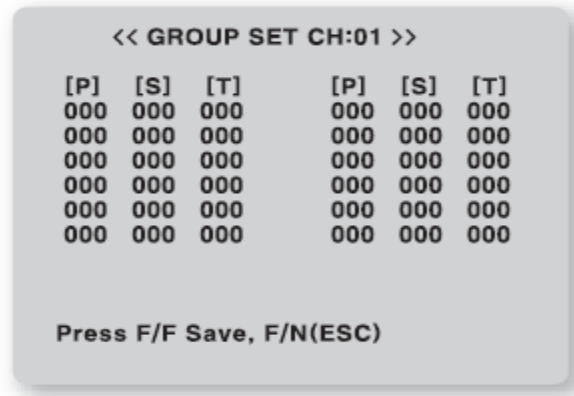
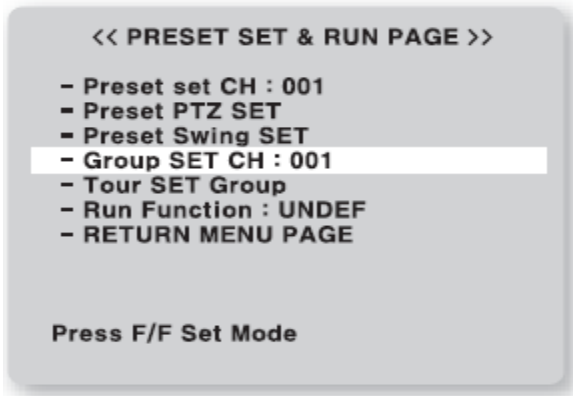

④ GROUP SET: User can set maximum 12 groups.  
 Select a channel then move to next page after pressing F/F key  
 ※ The Preset point in the Group that 12 Preset points are set is observed repeatedly and order with regular speed and time.

- [P] : Set Preset (1~250)
- [S] : Move speed (1~64)
- [T] : Delay time

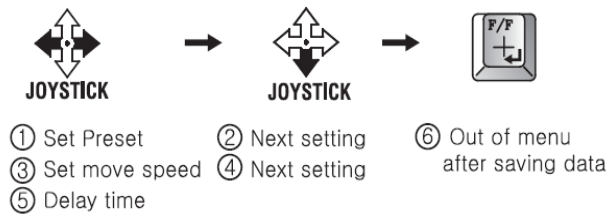

- ⑤ Tour SET Group: User can set continual Group motion that can be put 12 Groups in 1 Tour Move to the setting page if user presses F/F key on this menu
  - The Group user wants to set must be set firstly
  - ※ Setting is only possible when Preset is set first in the state of setting of Swing, Group, Tour, otherwise, it displays the message “Sorry Undefined”.
- ⑥ Run Function: Operate one of SWING/ \* Set / Stop order with a control keyboard without menu GROUP / TOUR / TRACE. (It is operated on the screen. automatically after end of OSD menu)
  - User can look at how to set TRACE at TRACE SET PAGE”
- ⑦ RETURN MENU PAGE: Move to a higher menu page when control the joystick Right/Left in the Selection of this menu.

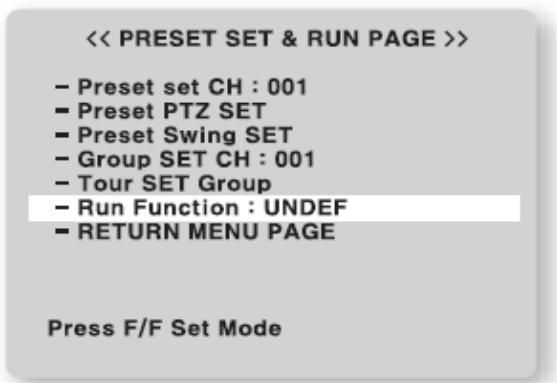

	RUN	STOP
Preset	1~250 +	
Swing	1(PAN) or 2(TILT) +	or
Group	1~12 +	or
Tour		or

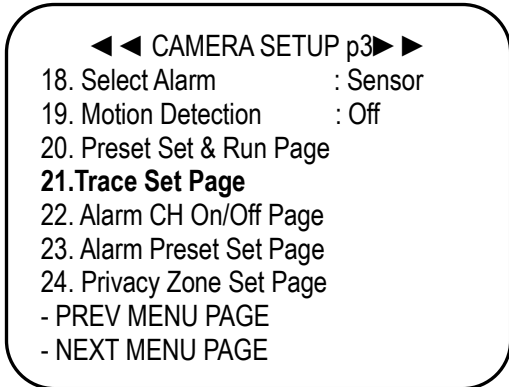

**21. TRACE SET PAGE**

Set TRACE.  
 User can regenerate and save a change of the unrestricted location of ZOOM In/Out and a position of the camera by hand-worked control with a joystick.  
 User can see the screen when moves the joystick to Right/Left after fixing the cursor on the menu

■ How to set TRACE

Move to [SET] after pressing

Check – Control scenes that user wants by hand-worked with a joystick after the message.

“Set Trace: OO%” on the middle of the screen. If user finishes this part, Move to [SAVE] with

It goes a higher menu after being saved data if user presses with a display of the message “Save TRACE”



## 22. ALARM CHANNEL ON/OFF

◀◀ CAMERA SETUP p3 ▶▶

- 18. Select Alarm : Sensor
- 19. Motion Detection : Off
- 20. Preset Set & Run Page
- 21. Trace Set Page
- 22. Alarm CH On/Off Page**
- 23. Alarm Preset Set Page
- 24. Privacy Zone Set Page
- PREV MENU PAGE
- NEXT MENU PAGE

■ What is the ALARM function? : It operate to observe the location of the camera which is memorized previously in the situation of the warning signal or trespassers by using a sensor.

- CH On/Off : Alarm Input – Each channel can be ON/OFF
- Alarm Relay : It can be set On or not when ALARM OUTOUT PORT operate wrong.
- Active Alarm : It selects ACTIVE OPEN or ACTIVE CLOSE by tangency when something is wrong. It is ACTIVE when ALARM INPUT is OPEN in ACTIVE OPEN, it is ACTIVE when ALARM INPUT is CLOSE in ACTIVE CLOSE

### - Resume Time Set :

It can select the delay time that the camera move to the place alarming to observe where wrong signal is sensed.

User can set it for 1sec to 180sec and operate GROUP, TOUR, SWING again in a preset time. SWING, GROUP, TOUR are operated

in a preset time when user stops the operating joystick in the case of not connecting with the ALARM.

Press SWING, GROUP, TOUR keys without stopping of the joystick to stop the operating completely

(\*Stopping the operating with the joystick affects the SET function.)

<< ALARM CHANNEL ON/OFF >>

- CH1 :Off -CH2 :Off
- CH3 :Off -CH4 :Off
- Alarm Relay :Off
- Active Alarm :Close
- Resume timeset :Off
- RETURN MENU PAGE

## 23. ALARM PRESET SET PAGE

◀◀ CAMERA SETUP p3 ▶▶

- 18. Select Alarm : Sensor
- 19. Motion Detection : Off
- 20. Preset Set & Run Page
- 21. Trace Set Page
- 22. Alarm CH On/Off Page
- 23. Alarm Preset Set Page**
- 24. Privacy Zone Set Page
- PREV MENU PAGE
- NEXT MENU PAGE

- The camera can move to a preset point automatically when something is wrong in each ALARM CHANNEL.
- Set a preset point firstly to move if anything wrong, then use that sets the preset number into each ALARM CHANNEL.
- PRESET is out of connecting in ALARM CHANNEL No.“0”
- User can select PRESET number 1 to 250 and set it.
- Home Position Preset

The camera automatically moves to where master user set when another user controls the camera to observe other area. (You can set 1~250 points)

### ■ Home Position Time

It sets the dwell time in Home Position Preset.

It automatically moves to where observes ordinarily in the regular time that Master user set in observation of other area ,if set Home Position Preset

(You can set 1~180sec. Set control Home Position Preset and Home Position Time together for using this function.)

<< ALARM PRESET SET >>

- CH : 001 - CH : 002
- CH : 003 - CH : 004
- Home Position Preset : 001~250
- Home Position Time : OFF/001~180
- RETURN MENU PAGE

※ You can set ALARM setting MENU not only in CAMERA SET MENU MODE, but also a KEYBOARD in direct

◀◀ CAMERA SETUP p3 ▶▶

- 18. Select Alarm : Sensor
- 19. Motion Detection : Off
- 20. Preset Set & Run Page
- 21. Trace Set Page
- 22. Alarm CH On/Off Page
- 23. Alarm Preset Set Page
- 24. Privacy Zone Set Page**
- PREV MENU PAGE
- NEXT MENU PAGE

## 24. PRIVACY ZONE SET

☞ This function does not work on 27X speed dome camera.

Max 16 privacy zones can be configured for the protection of privacy.

### ■ How to set privacy zone

In <<PRIVACY ZONE SET>> menu, select the channel that you want by a joystick, then move to the next page if you press the [F/F] key

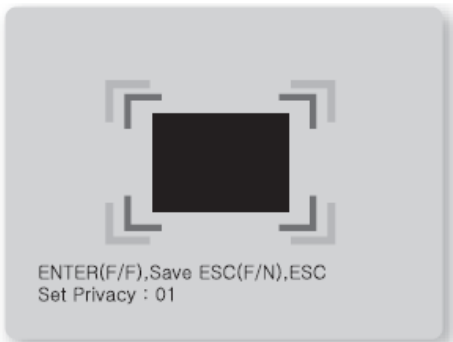



①  Select a Channel

②  : Select Set/On/Off/Del

**Set** : Set a new privacy      **On** : Display privacy area  
**Off** : Hide privacy areas      **Del** : Delete privacy areas

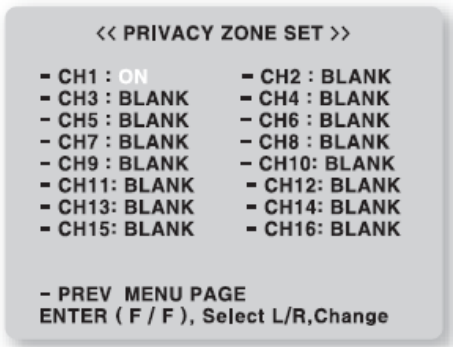
**It only displays "set" where in the channel to be not set PRIVACY ZONE.**



③  : Check, Next page

④ Fix the black square on the middle of area that you want to hide by a joystick, then go back to the previous page by [F/F] key after controlling the size of the square by [Z/I], [Z/O] key and saving it.

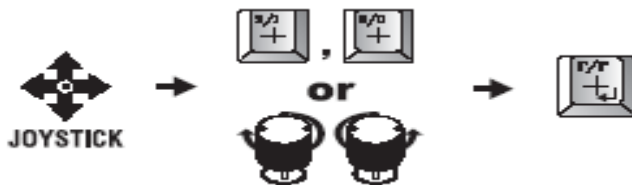

Set the position    BOX Extension / Reduction    Check

⑤ The Channel is changed BLANK to 'OFF'.  
 The screen displays the black square, if you change the CH ON' as the left picture.



⑥ Out of OSD MENU  + 



◀◀ CAMERA SETUP p4 ▶▶

(27x -33x/37x)

**24 - 25. Auto Tilt Mode** : Off  
25- 26. Smart Pan/tilt : ON  
26- 27. Manual P/T Speed : Medium  
27- 28. Auto Refresh Time :1day  
28- 29. Shortcut Key : On  
29- 30. Use Password :Off  
30- 31. Language :English  
31- 32. Factory Reset Warning  
- PREV MENU PAGE

**24-25. AUTO TILT MOVE**

The PAN is turned in a 180° degree arc automatically when the angle of the camera moves down to the maximum degree, therefore, it is possible to track objects continuously



◀◀ CAMERA SETUP p4 ▶▶

(27x -33x/37x)

24 - 25. Auto Tilt Mode : Off  
**25- 26. Smart Pan/tilt** : ON  
26- 27. Manual P/T Speed : Medium  
27- 28. Auto Refresh Time :1day  
28- 29. Shortcut Key : On  
29- 30. Use Password :Off  
30- 31. Language :English  
31- 32. Factory Reset Warning  
- PREV MENU PAGE

**25-26. SMART PANTILT**

It is a function that P/T speed is getting slower as Zoom in.

It is hard to observe objects with the high PANTILT speed in operating of Zoon In

This function makes the speed less automatically for the effective observation

◀◀ CAMERA SETUP p4 ▶▶

(27x -33x/37x)

24 - 25. Auto Tilt Mode : Off  
25- 26. Smart Pan/tilt : ON  
**26- 27. Manual P/T Speed : Medium**  
27- 28. Auto Refresh Time :1day  
28- 29. Shortcut Key : On  
29- 30. Use Password :Off  
30- 31. Language :English  
31- 32. Factory Reset Warning  
- PREV MENU PAGE

**26-27. MANUAL P/T SPEED**

User can control the maximum speed in controlling of up and down.

It can be set Low, Medium, Max and one turn (360°/sec) is possible in Max.

◀◀ CAMERA SETUP p4 ▶▶

(27x -33x/37x)

24 - 25. Auto Tilt Mode : Off  
25- 26. Smart Pan/tilt : ON  
26- 27. Manual P/T Speed : Medium  
**27- 28. Auto Refresh Time :1day**  
28- 29. Shortcut Key : On  
29- 30. Use Password :Off  
30- 31. Language :English  
31- 32. Factory Reset Warning  
- PREV MENU PAGE

**27-28. AUTO REFRESH TIME**

Auto refresh can be set from 1 to 7days (each) for good focus performance

◀◀ CAMERA SETUP p4▶▶

(27x -33x/37x)

- 24 - 25. Auto Tilt Mode : Off
- 25- 26. Smart Pan/tilt : ON
- 26- 27. Manual P/T Speed : Medium
- 27- 28. Auto Refresh Time :1day
- 28- 29. Shortcut Key : On**
- 29- 30. Use Password :Off
- 30- 31. Language :English
- 31- 32. Factory Reset Warning
- PREV MENU PAGE

**28-29. SHORTCUT KEY**

The Shortcut Key can make some of the functions to perform faster and easily.

★ How to use shortcut key ( All protocols is operated it at the same way )

Function	Operation	Function	Operation
Group 1	51 + Preset	Run Trace	66 + Preset
Group 2	52 + Preset	Run Spiral	67 + Preset
Group 12	62 + Preset	B/W Mode	68 + Preset
Run Tour	63 + Preset	Color Mode	69 + Preset
Run Pan Swing	64 + Preset	OSD Menu ON/OFF	95 + Preset
Run Tilt Swing	65 + Preset		

◀◀ CAMERA SETUP p4▶▶

(27x -33x/37x)

- 24 - 25. Auto Tilt Mode : Off
- 25- 26. Smart Pan/tilt : ON
- 26- 27. Manual P/T Speed : Medium
- 27- 28. Auto Refresh Time :1day
- 28- 29. Shortcut Key : On
- 29- 30. Use Password :Off**
- 30- 31. Language :English
- 31- 32. Factory Reset Warning
- PREV MENU PAGE

**29-30. USE PASSWORD**

- input the password
- available set On/Off mode; off mode is factory set
- press the F/F button as On mode
- A window will be pop-up for input Old and New passwords. Old password is set as '0000'. To input a new password, use the joystick as up, down, right, and left
- Press F/F button to save the new password. The new password will be needed when access the OSD mode

◀◀ CAMERA SETUP p4▶▶

(27x -33x/37x)

- 24 - 25. Auto Tilt Mode : Off
- 25- 26. Smart Pan/tilt : ON
- 26- 27. Manual P/T Speed : Medium
- 27- 28. Auto Refresh Time :1day
- 28- 29. Shortcut Key : On
- 29- 30. Use Password :Off
- 30- 31. Language :English**
- 31- 32. Factory Reset Warning
- PREV MENU PAGE

**30-31. LANGUAGE**

English, Portuguese, Polish

◀◀ CAMERA SETUP p4 ▶▶

(27x -33x/37x)

24 - 25. Auto Tilt Mode : Off  
25- 26. Smart Pan/tilt : ON  
26- 27. Manual P/T Speed : Medium  
27- 28. Auto Refresh Time :1day  
28- 29. Shortcut Key : On  
29- 30. Use Password :Off  
30- 31. Language :English

**31- 32. Factory Reset Warning**

- PREV MENU PAGE

**31-32. FACTORY RESET WARNING**

Please be careful of that all setting data of OSD MENU are reset into the first default when operates FACTORY RESET WARNING.

The setting data of Preset, Swing, Group, Tour, Trace, also is deleted all

# IV. Functional Setting by the Keyboard

## 1. Preset setting

You can set Preset point up to 250.

### ① Preset Input.

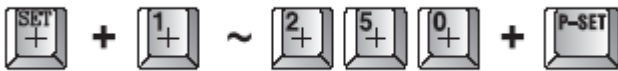

Preset setting can be set 1 to 250 sequentially after moves the camera to where you want

### ② Preset Move



The camera moves to the preset point, if you press Preset No. that you want and **P-SET Key**

### ③ Delete a separate Preset

Go on in order as below when the sound is heard in 3 seconds after pressing **CLR Key**



Ex) Delete 5<sup>th</sup> Preset



(Waiting for 3seconds)

### ④ Delete all Preset

Go on in order as the right picture when the sound is heard in 3 seconds after pressing **CLR KEY**



(Waiting for 3seconds)

## 2. Swing setting

### ① Swing Input

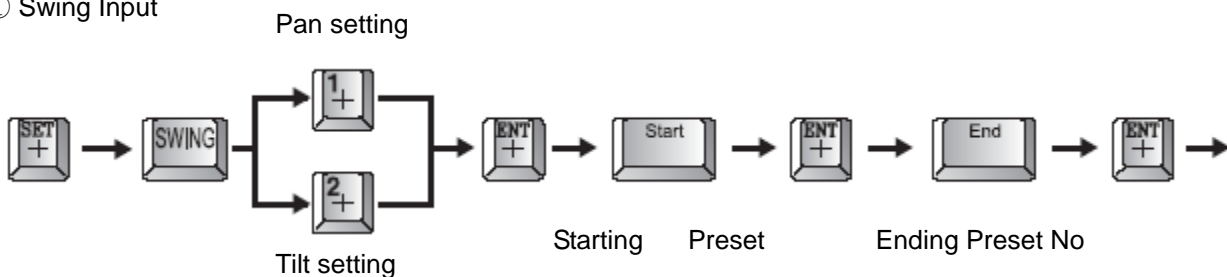

Set the delay time (1~127sec)

Set the move speed (1~64 steps)

② Operation of Swing

③ End of Swing



(Run Pan) (Run Tilt)



3. Group setting

① Start Group setting mode

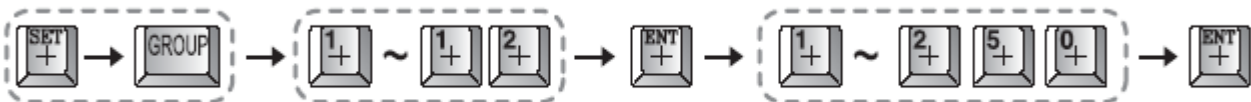

Start the Group setting mode

Select the Group in 1~12

Select in Preset No.1~250 and input them.



Move Speed:  
The Speed from A to B  
64=High, 1=Low

Dwell Time:  
The dwell time at the point of  
A or B before the move. (sec)

- Set Preset No. again if you want to input it continuously.
- Set a GROUP again from the first after ending with **SET Key**, if you would like to finish Preset input in one group to input next Group.

② Start a Group

③ Stop the Group



You can stop it when pressing **Group key** or using a joystick

4. Tour setting

① Tour set mode



Start the Tour set mode

Select a Group in 1 ~ 12

■ Repeat input in continual input

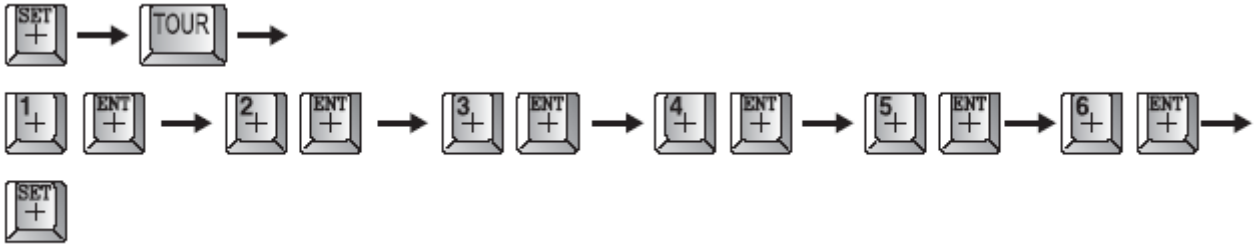

EX). Register Group No. 1, 3, 6 as Tour

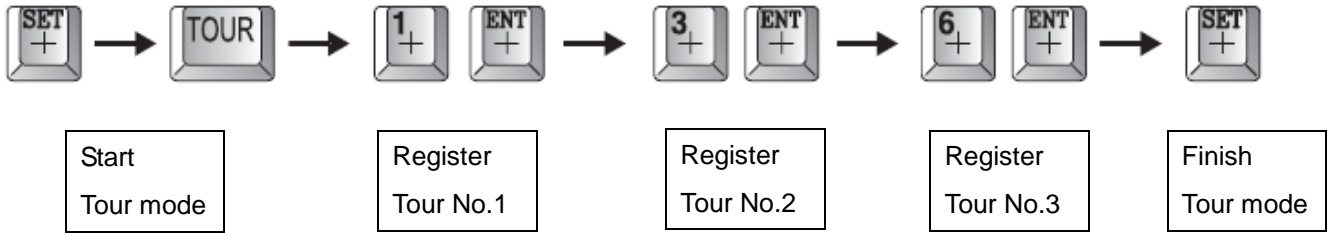

② Start / End Tour



③ Delete Tour



5. Spiral Function

It is a function to observe objects in the spiral direction.

- ① Spiral observation 'ON'
- ② End

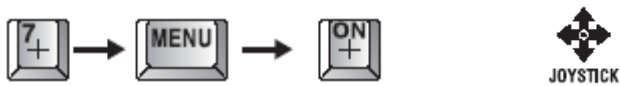

6. PTZ Trace

It memorizes P/T/Z motions for 200sec, then operates them at the same Trace.

- ① Start / End Trace



- ② Set Trace

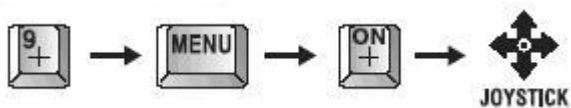

- ③ Delete Trace



# V. OSD MESSAGE DESCRIPTION

## 1. PRESET MESSAGE

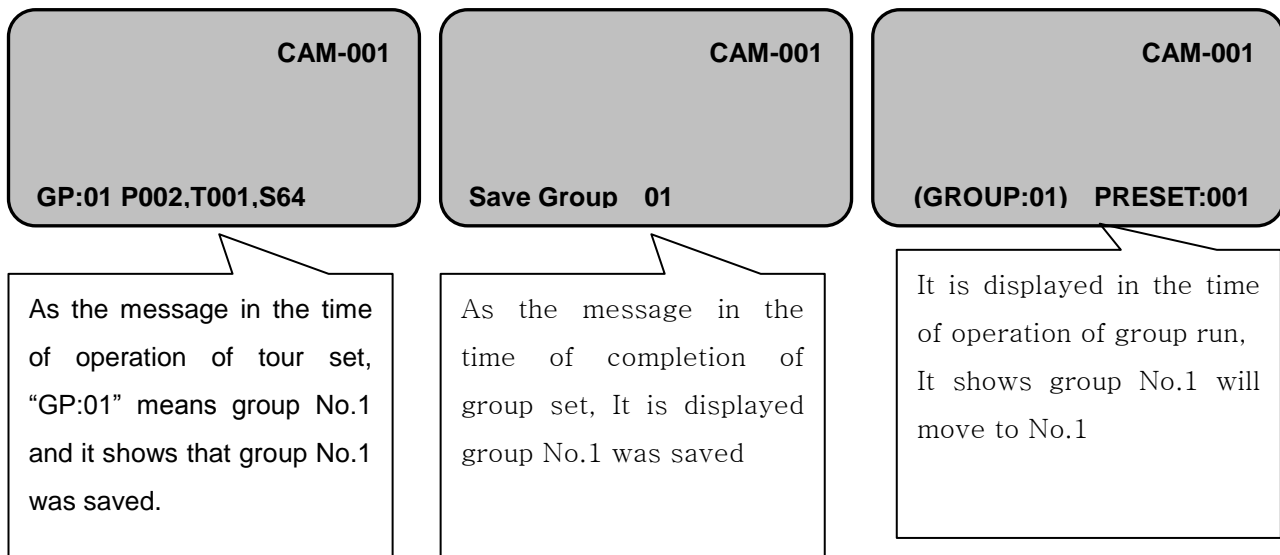
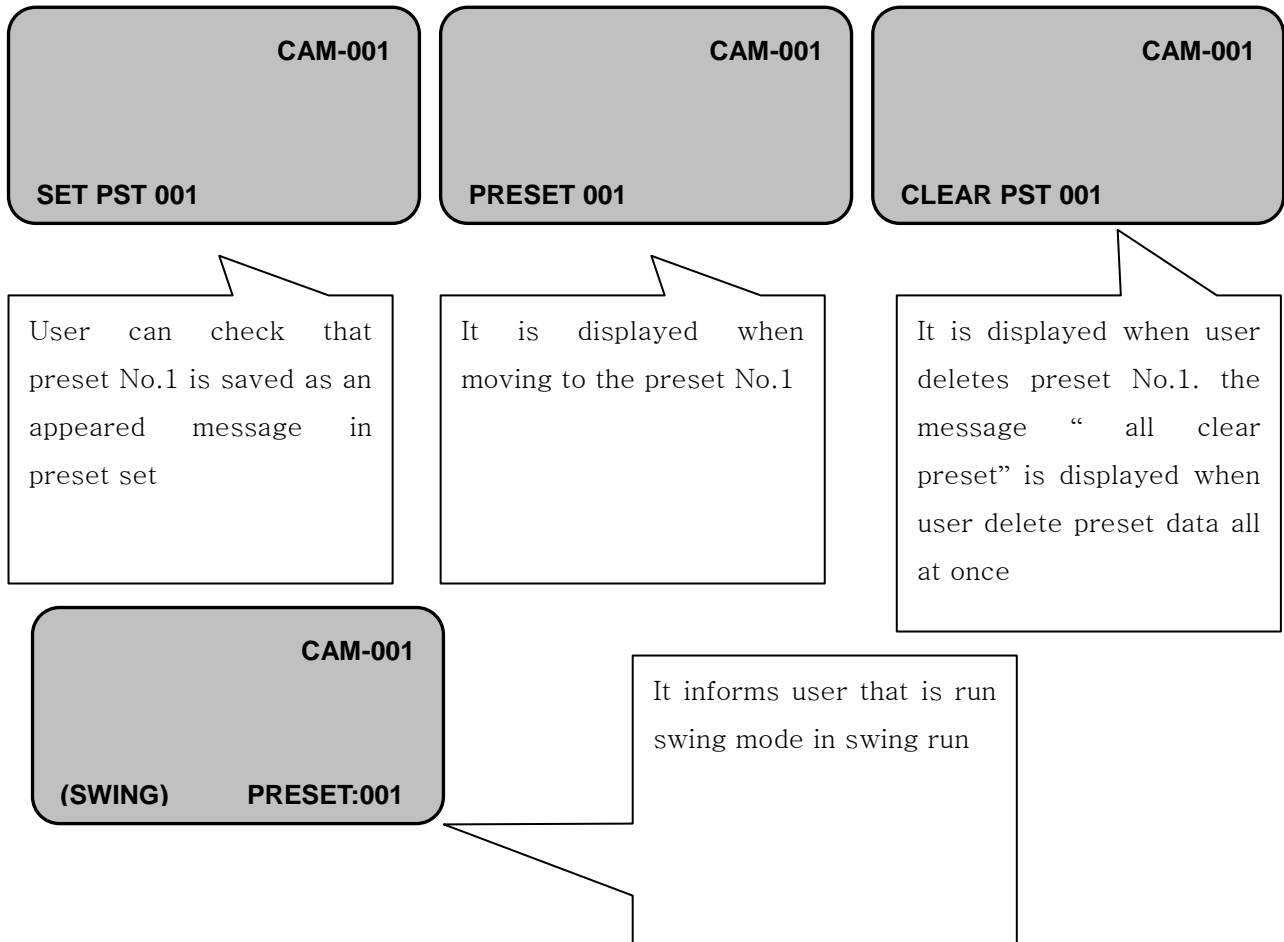

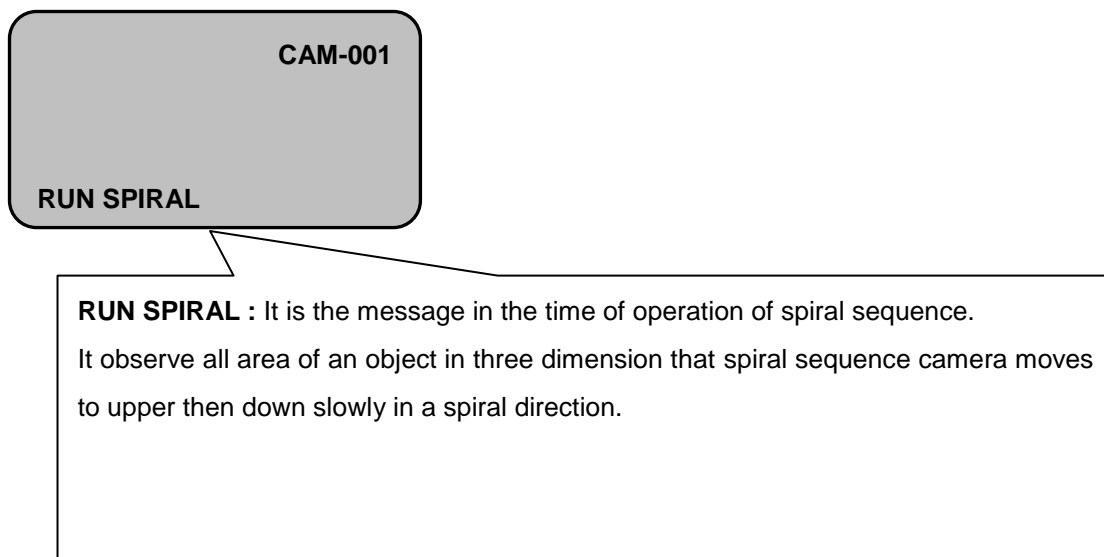
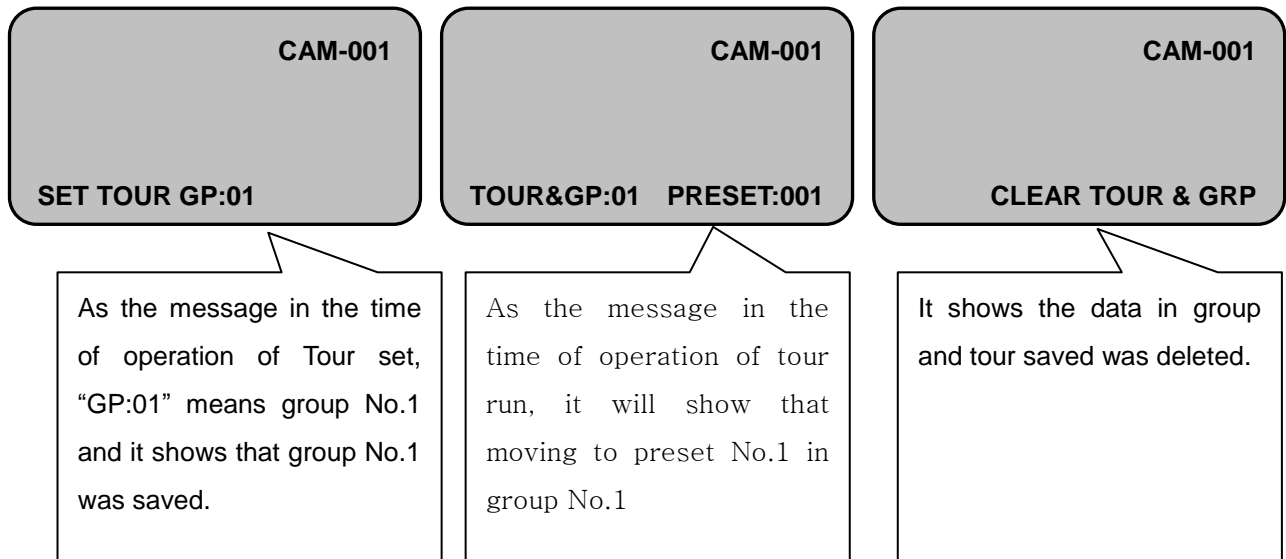



## VI. TROUBLE SHOOTING

1. You must turn off the power switch before installation of this equipment
2. Avoid installation places where it is the ultimate cold, hot, and humid.
3. Use a power supply of AC24V, 1.5A output.
4. Please be careful that you connect respective wires without mismatching in installation.
5. Check the controlled cable's insulation connecting to exterior and supply to power sources.
6. Please keep the equipment from impact and strong rolling in installation or in use because of the caution of troubles.

TROUBLE SHOOTING	CHECK POINT	MAINTENANCE
Power do not turn on	Does the electric power supply into the equipment normally?	Check either LED is lit or not in the connector part of back box.
Power turned on but do not operate.	In operating, Does the LED beside power switch light to red?	<ul style="list-style-type: none"> <li>● Check the connecting status of data cable, if it is not lit.</li> <li>● If it is lit, check address and communication speed setting of DIP switches.</li> </ul>
	Did you select to RS485 or RS422 exactly?	Check the status at number 2 of option DIP switches.
The acting of pan/tilt is not good.	Did you turn on the ending terminal register? (The ending terminal resister can be switch on/off, if you loose cover of dome.)	Switch on the ending terminal resister of camera to be set in most far away.
Either it is not clean on screen or it is appeared rolling TV lines on screen.	Is the power supply AC24V, 1.5A output?	Change the adapter has higher current charge than used adapter.
It is not focus on the object by manual.	Did you change min. distance in the set menu?	Change min. distance in the set menu.
It is continuously appeared error message of " P/T POSITION ERROR"	Did the under body of camera press or put between others?	Get rid of something that press camera, and check either camera is rotating in softly or not.
It is continuously appeared error message of " SORRY NOT MEMORY"	Did you set the related function?	Please refer to manual book and setting the function you want
It does not alarm relay ON in active alarm state.	Did you set ON the alarm relay in the set mode?	Please select on to enable alarm relay in the set mode
Even if sensor is normal, it is activated abnormal.	Is it correct alarm active setting status and sensor is either open or close?	Please set alarm active mode setting as to correct to connect status of sensor (it means either sensor is open or close) in the set mode.

When it occurred alarm state, it is not exactly presser position or different.	Did you set the preset in the set mode?	Check setting status of the alarm preset in the set mode.
When it activate alarm state, there is no sign on the keyboard controller	Did you use the exclusive control keyboard?	It is need to use an exclusive control keyboard so that the alarm sound is activated on the controller
	Yes, I do.	Please select on to enable alarm of the related camera.

# VII. DIMENSIONS

## Wall mount bracket

### Outdoor Type

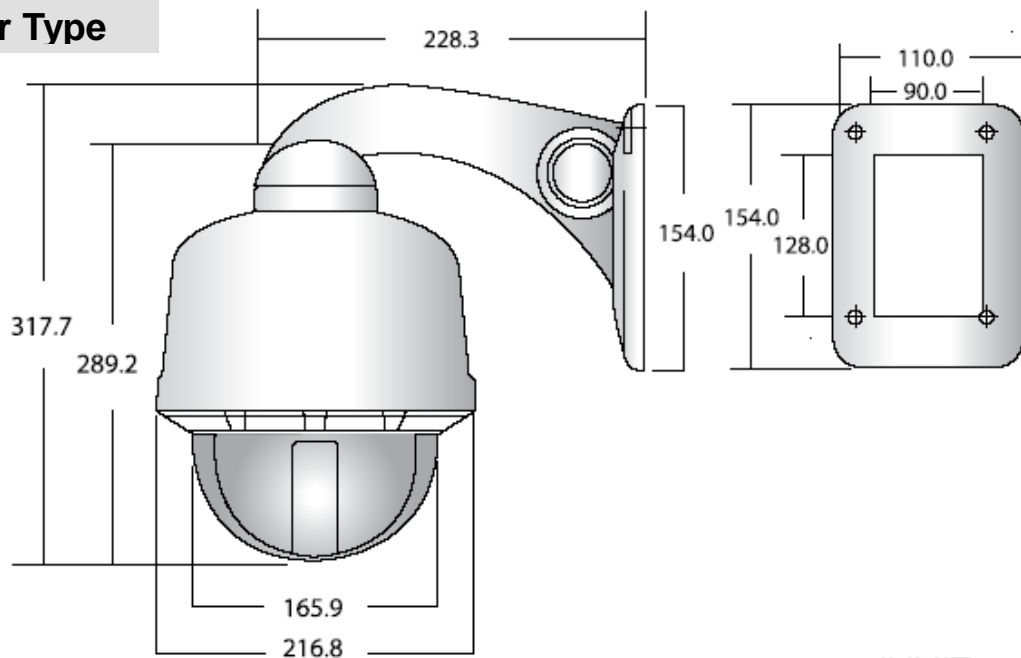

### Indoor Type

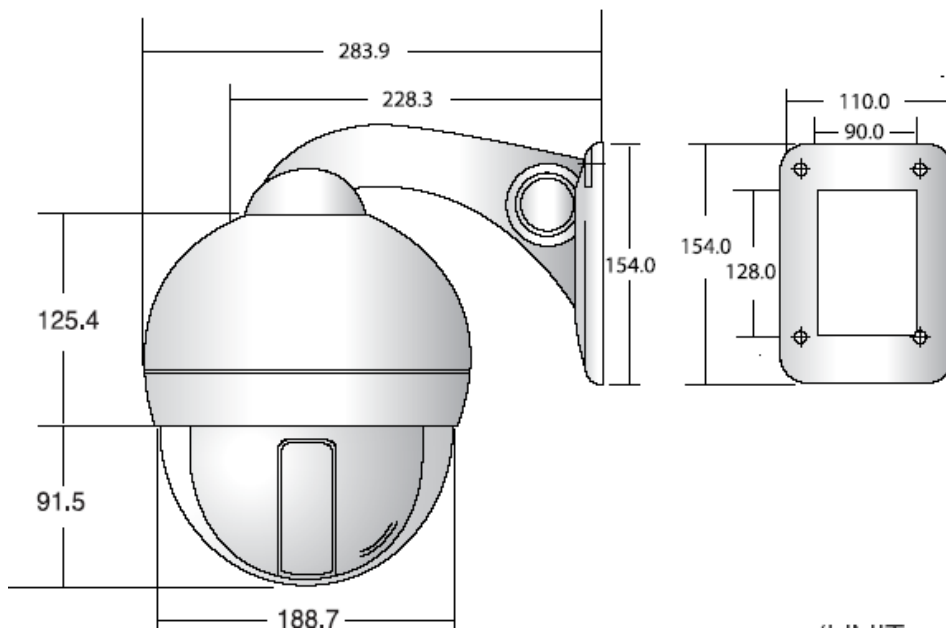

# Ceiling mount bracket

## Indoor Type

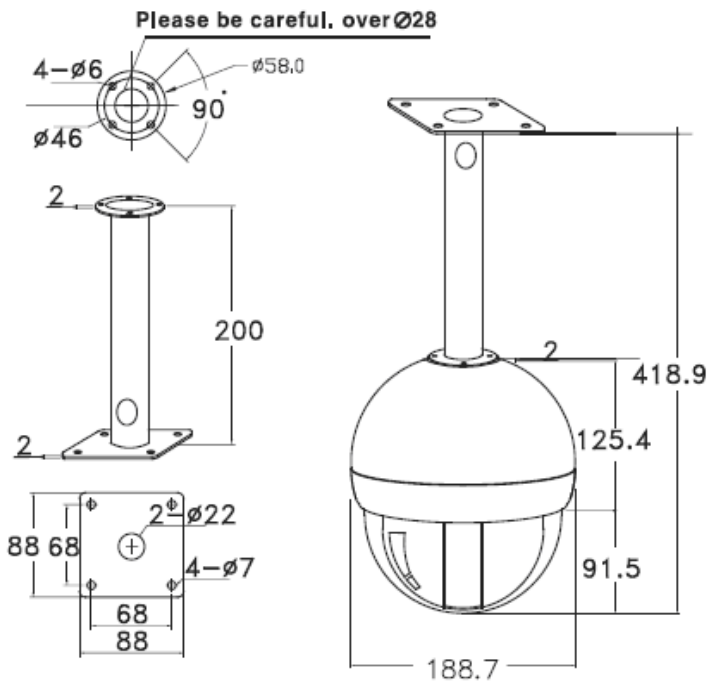

## Outdoor Type

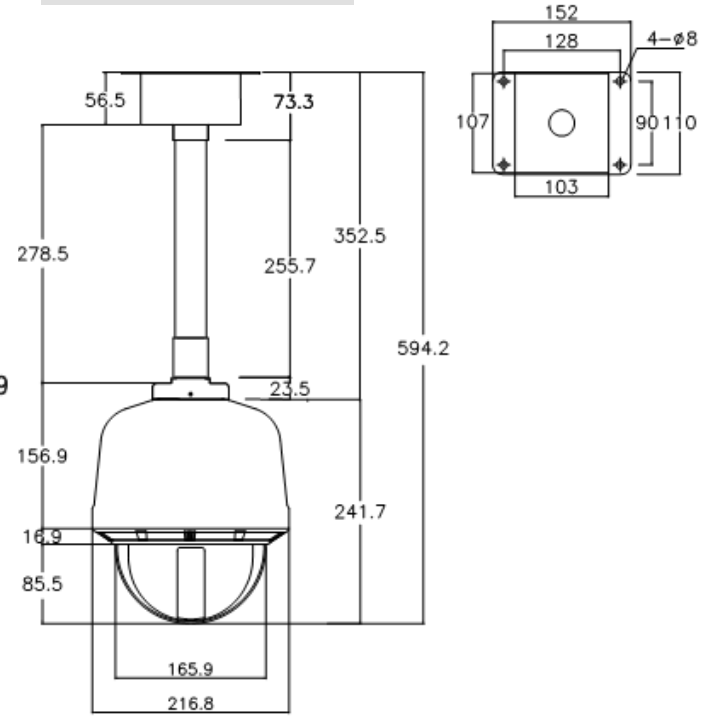

## In-ceiling mount bracket

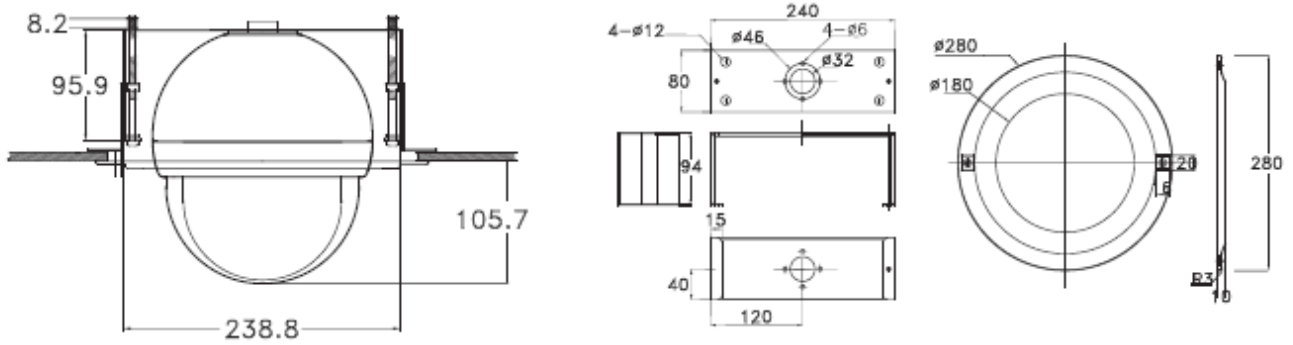

# VIII. ASSEMBLY

## DSC-30EWP Wall mount bracket

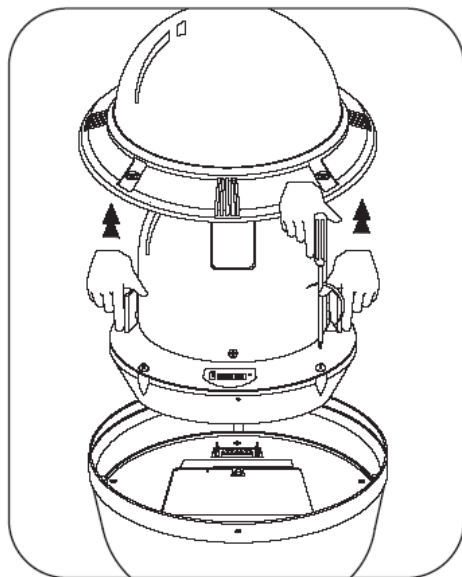

① Remove the main body of camera from the housing

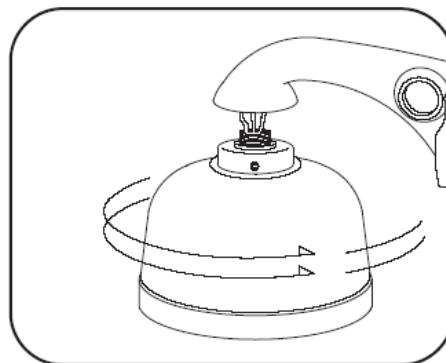

③ Fix the upper cover into a wall bracket with turning it in the same direction as the picture

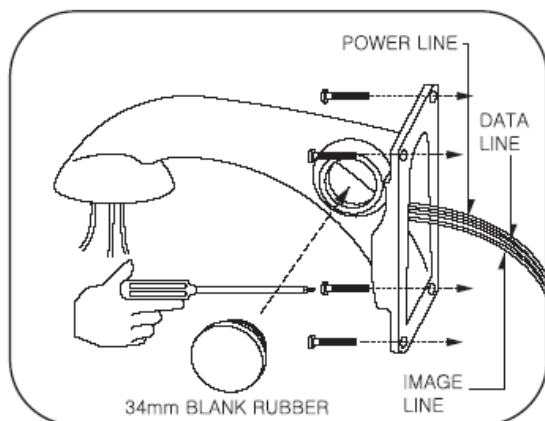

② Fix four bolts after connecting each line and block up the hole of the bracket's body with 34mm block rubber.

Connect the line as above the picture when you set in the concrete structure such as the wall and connect TAB/P1/11" flexible connector (28Ø)

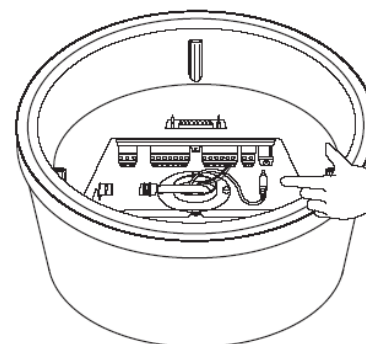

④ Connect the data cable, video cable and power source cable.

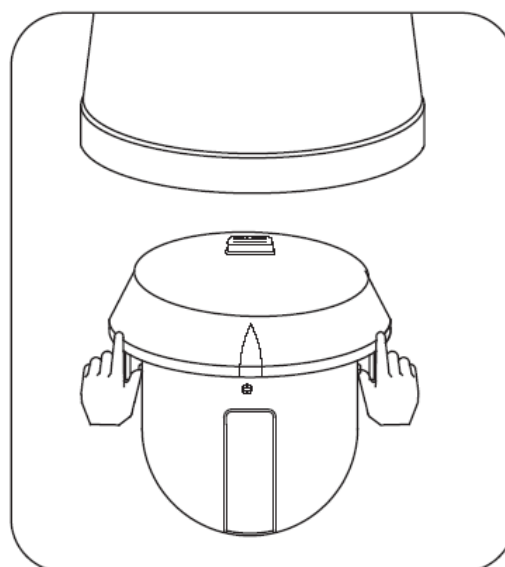
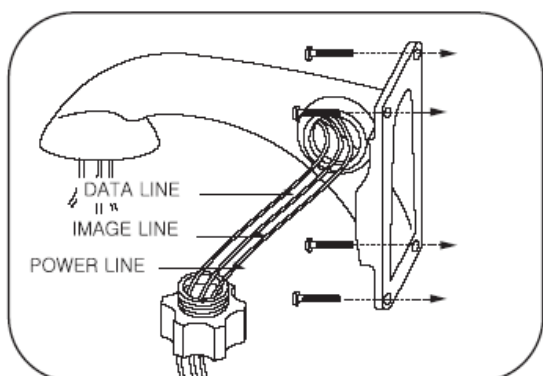

⑤ Unite the body of the camera to the housing.

# DSC-20ECP Wall mount bracket

## Assembly of outdoor dome with pole mount pendant

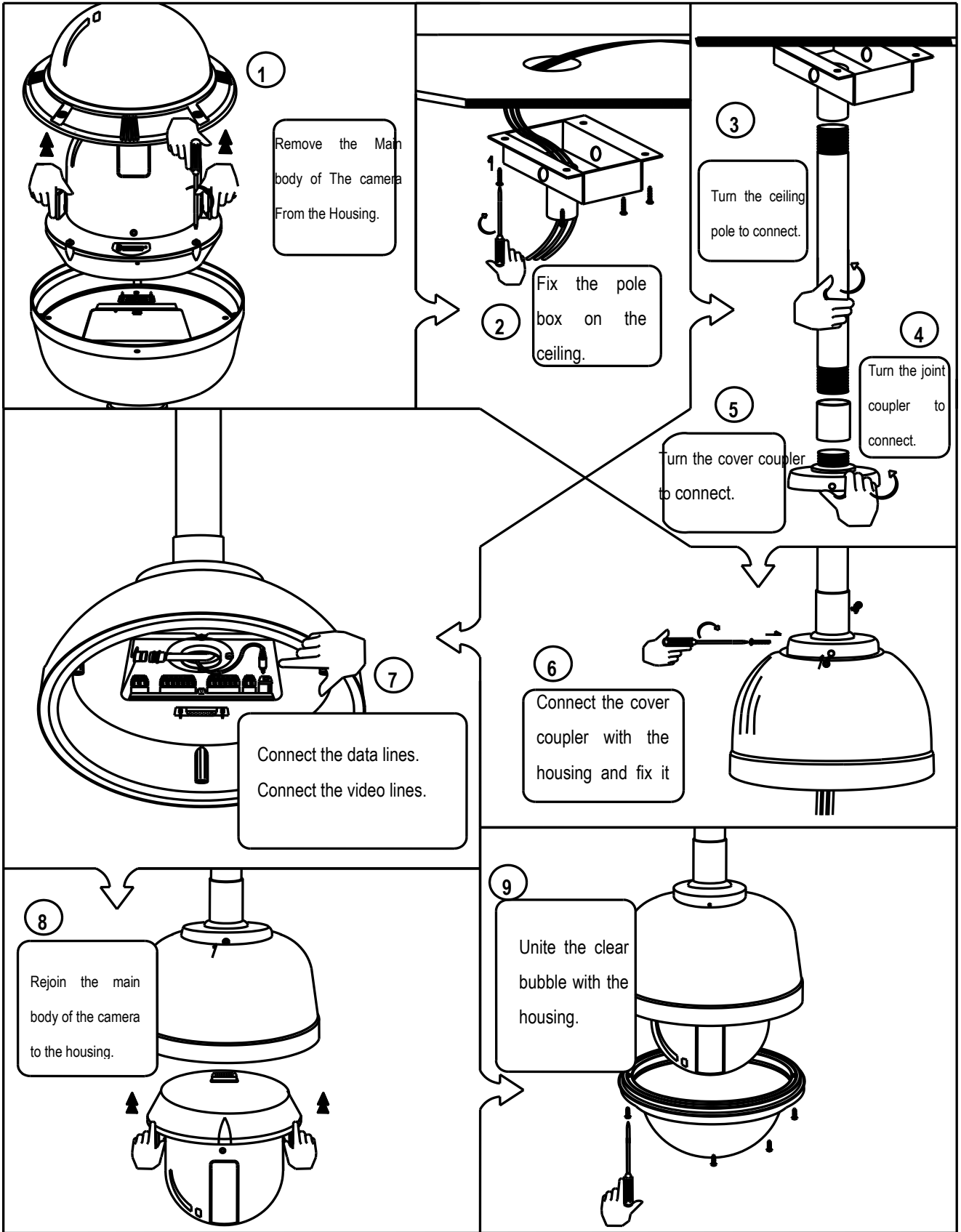

# Main & Sub Keyboard configuration

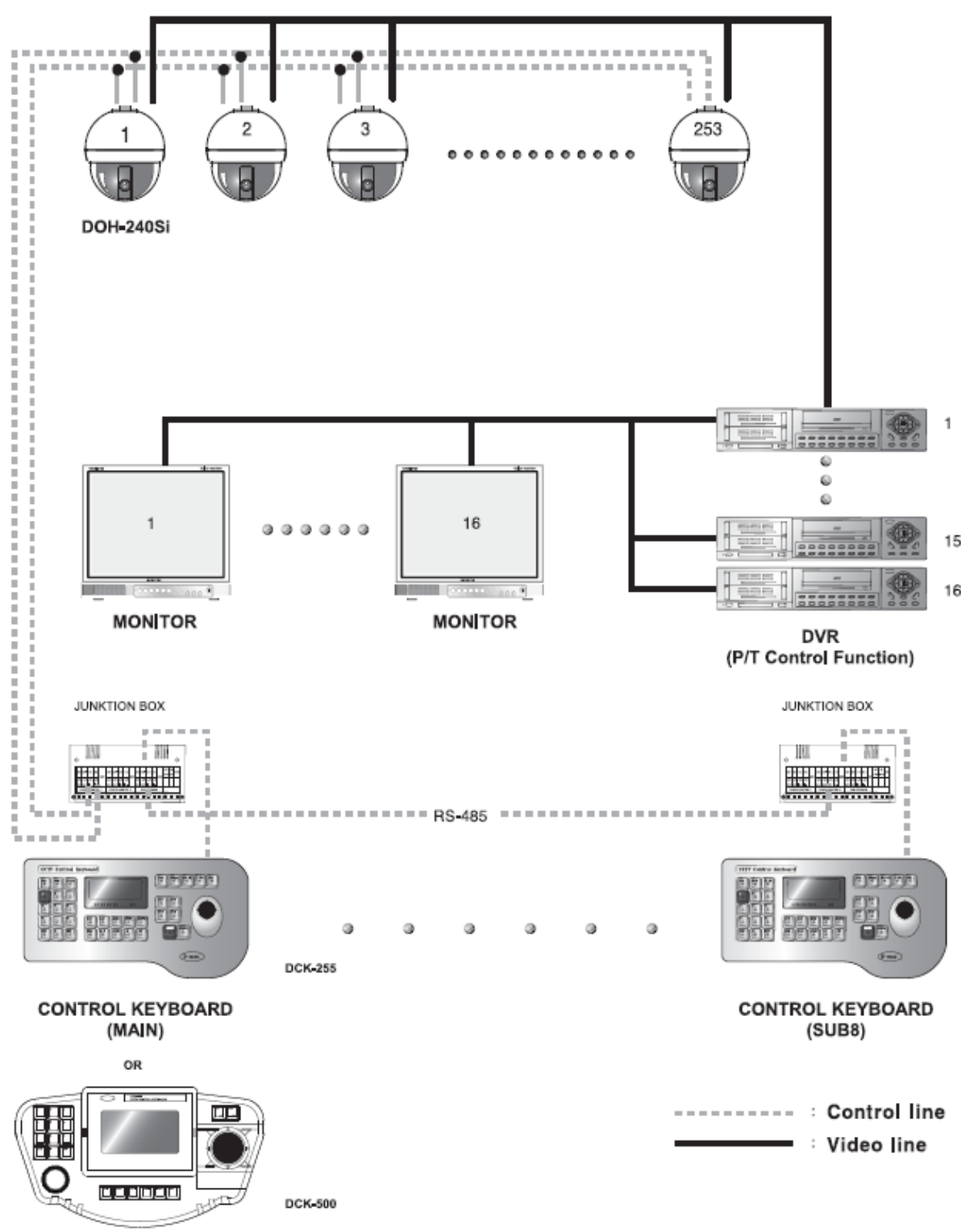

## IX. SPECIFICATIONS

MODEL	27X Zoom <input type="checkbox"/>	33X Zoom <input type="checkbox"/>	37X Zoom <input type="checkbox"/>
Image sensor	1/4" Sony Super HAD CCD		
Effective pixels	NTSC 768(H) X 494(V), PAL 752(H) X 582(V),		
Horizontal resolution	Color : 600 TVL, B/W 700 TVL		
Lens (Digital Zoom)	27x Optical zoom(16x), f =3.5 –94.5mm	33x Optical zoom(16x), f =3.5 –115.5mm	37x Optical zoom(16x), f =3.5 –129.5mm
Angle of view	H : 55.5° ~2.24° , V : 42.5°~1.79°	H : 55.5° ~1.77° , V : 42.5°~1.33°	H : 55.5° ~1.59° , V : 42.5°~1.19°
Minimum illumination	0.7 Lux , 0.1Lux(D&N), Min 0.00004Lux(DSS) / F1.6 (50IRE)		
Luminance S/N ratio	More than 52dB		
Video output	1 Vp-p Composite video output 75Ω		
Focus mode	Auto / Manual / Oneshot		
DNR	Off / Low / Middle / High		
Back Light Control	BLC / HLC /WDR		
Shutter speed	Auto / 1/120 ~ 1/120,000 sec		
Sharpness control	Level (0 – 10)		
Stabilizer	On/Off		
Alarm in/out	4 Inputs / 1 Relay Output		
Pan/Tilt angle	360° Endless / 92°		
Preset point	250 Presets		
Preset Speed	Max 360°/sec (64 Levels)		
Privacy zones masking	Not available	16 Zones	16 Zones
Operating temperature / Operating humidity	– 40°C ~ 50°C (–40°F ~ 122°F) (Outdoor Model) / Less than 90%RH – 10°C ~ 50°C (–14°F ~ 122°F) (Indoor Model) / Less than 90%RH		
Communication system	RS-485		
Operating Fan/Heater	Over than 45°C / Less than 5°C (Only Outdoor Model)		
Dimensions	188.7mm(Diameter) x 216.9(Height) mm (Indoor Model)		
	216.8mm(Diameter) x 289.2(Height) mm (Outdoor Model)		
Weight	About 5.2Kg (Outdoor Model), About 3.1Kg (Indoor Model)		
Construction	Aluminum body , Clear vandal bubble (PC) (Outdoor Model)		
	ABS body , Clear vandal bubble (PC) (Indoor Model)		
Power consumption	21W (Max) Indoor Model / 18W (Max) Outdoor Model		
Power supply	AC24V, 60/50 Hz		









---

DISTRIBUTED BY